

Uniden®

UH9050 **UHF CB Transceiver**

For more exciting new products please visit our website:
Australia: www.uniden.com.au

OWNER'S MANUAL

Contents

Introduction	4
Controls & Connectors	6
Indicators	9
Included with your UH9050	10
Optional Accessories	11
DIN Installation	12
Connecting the Microphone	15
Mounting the MIC Hanger	16
Operation	18
Turning on the Power	18
Setting the Volume	19
Transmitting	19
Smart-Key Function	19
Voice Enhancer Setting (EQL)	20
TRIPLE Watch	21
Selecting a Channel	22
Channel Banks - Using the POLICE button	22
CTCSS (Continuous Tone Coded Squelch System)	23
DCS (Digital Coded Squelch)	23
Using Repeater Channels	24
Setting the Squelch Level	25
Operating the UHF CB Radio in Duplex Mode	26
Priority Watch	26
Programming the Instant Priority Channel-1	27
Programming the Instant Priority Channel-2	27
Recalling the Instant Channel	27
Scanning	28
Add/Remove Channels from SCAN Memory	28
Open Scan (OS) Mode	29
Group Scan (GS) Mode	30
Master Scan Mode	31
Selecting the Call Tone (Wake Up Tone)	33
Busy Channel Lockout	33
Roger Beep	34
Key Beep On/Off	34
Alpha Tag	35
Internal Speaker	35
Backlight Colour	36
Backlight Level	36
MIC Contrast Level	37
Recording Mode	37
Scramble	38

Contents

Operation - Special Features	39
100 User Programmable RX Channels	39
Manually Programme a RX Channel	39
Search Extra Channel Range and Programme a RX Channel	40
Store a Police/Fire frequency to a RX Channel	41
Instant Replay	42
Turning Instant Replay On/Off	43
Selective Calling	43
Programming the Selcall ID for your UH9050	44
Storing Selcall IDs of other users to the ID Memory	44
Tone Calling (Making a Selcall Call)	45
Receiver Quiet (TSQ) Mode	46
To Activate/Deactivate Tone Squelch (TSQ) on a Channel	46
Receiving a Selcall	46
Scanning Tone Squelched Channels	47
Group Calling	48
Selcall ID Format	48
Selcall Settings	49
Tone Period	49
Lead-in Delay	49
Lead-in Delay Programming	50
Lead-in Tone	50
Alarm mode	51
Call Alarm - Continue Mode	51
Group Call Mode	51
SELCALL Tone Frequency List	52
CTCSS Codes Table	52
DCS Codes Table	53
Channel Bank List - Police (POL)	54
Channel Bank List - Fire	55
UHF CB Channel Guidelines	56
UHF CB Channels & Frequencies	57
Warranty	59

Introduction

The Uniden UH9050 is designed to provide you with years of trouble free service. Its rugged components and materials are capable of withstanding harsh environments. Please read this Operating Manual carefully to ensure you gain the optimum performance of the unit.



NOTE

The citizen band radio service is licenced in Australia by ACMA Radio-communications (Citizen Band Radio Stations) Class Licence and in New Zealand by MBIE General User Licence for Citizen Band Radio and operation is subject to conditions contained in those licenses.

Features

- UHF-CB Narrow Band (NB) Transceiver Radio¹
- 80 Channel
- 5W Transmission Power
- Built-in AVS Circuitry³
- Duplex Capability¹
- Built-in Selective Calling (SELCALL) Feature with Alpha Tag
- Roger Beep Function On/Off
- 10 Different Call Tones

Special Features

- 100 Extra User Programmable Receive Only Channels with Alpha Tag²
- Pre-Programmed Police, Fire & Ambulance Frequencies²
- Instant Replay of Recent Received Signals

Control Features

- Optional Remote LCD Speaker Microphone (Remote SPK/MIC) with Extension Cable
- LCD Display with 7 Backlight Colours
- LCD Brightness
- Mobile DIN Size with DIN Sleeve and Removable Bracket
- +12V to +24V DC Power Input
- Under and over voltage alert function
- Signal Strength/ Power Meter
- Volume Control
- External Speaker Jack
- Power On/Off Push Switch

- Front and Rear MIC Jacks for increased mounting options
- Variable Squelch Level adjust with optional Remote SPK/MIC
- Voice Scramble

Channel Features

- Channel Select
- Instant Channel Programming
- One touch Instant Channel recalling
- Triple Watch with Instant Channel
- Group Scan and Priority Channel Watch
- Open Scan
- MASTER Scan
- Scan Channel Memory On/Off separately with Open Scan, Group Scan
- Busy Channel Lock-out Function
- 38 Built-in CTCSS (Continuous Tone Coded Squelch System) codes
- 104 additional DCS (Digital Coded Squelch) codes that are user selectable

¹ Refer to p.52 - p.58 for channel information

² Available frequencies & channels are within 400-520MHz Band only in 12.5kHz steps. Police, Fire & Ambulance reception is unencrypted analogue.

³ AVS - Automatic Volume Stabilizer detects and manages incoming audio to comparable levels.

Introduction

Preventive Maintenance

The following system checks should be made every six to twelve months:

- Check the Standing Wave Ratio (SWR).
- Inspect the tightness of all electrical connections.
- Inspect the antenna coaxial cable for wear or breaks on the shielding.
- Inspect the tightness of all screws and other mounting hardware.

Troubleshooting

Should the unit malfunction or perform poorly, follow these procedures:

If the transceiver is completely inoperative: Check the power cord and fuse.

If there is trouble with receiving: Check the VOLUME control setting. Be sure the SQUELCH is adjusted properly. Possibly the radio is over-squelched.

If there is trouble with transmitting: Check that the transmission line (coaxial cable) is securely connected to the ANTENNA connector. Check that the antenna is fully extended for proper operation. Check that all transmission line (coaxial cable) connections are secure and free of corrosion.

Controls & Connectors

UH9050 Base Front View

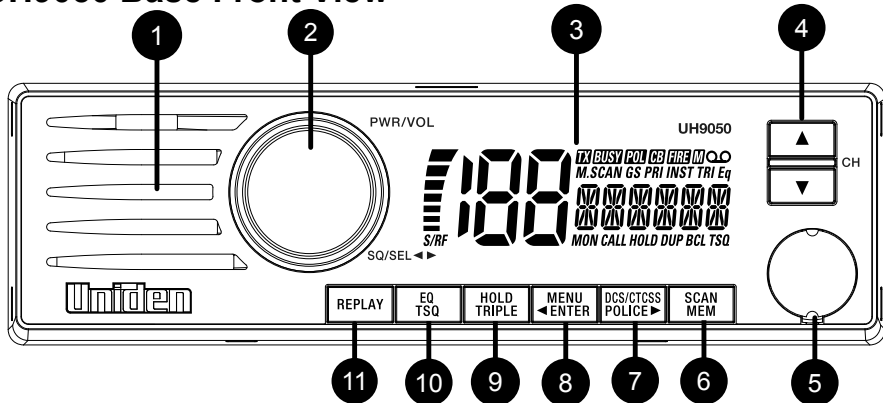

Controls and Connectors

- 1 Speaker
- 2 **PWR/VOL** - Power On/Off Push control/
Rotary Volume Control
- SQ/SEL** - Rotary Squelch control/Select
Button
- 3 Liquid Crystal Display (LCD)
- 4 / - Channel Down Button/Select
Down Button / Channel Up
Button/Select Up Button
- 5 **MIC** - Front Microphone Jack
- 6 **SCAN/MEM** - Scan and Memory button
- 7 **DCS/CTCSS** - DCS and CTCSS Tone
button.
- /POLICE** - CB/Fire/Police button.
 - Move selection right
- 8 **MENU/ENTER** - Menu and Select button
 - Move selection left
- 9 **HOLD/TRIPLE**- Hold and Triple watch
button
- 10 **EQ/TSQ** - Equalizer and Tone Squelch
Channel
- 11 **REPLAY** - Replay Function button

UH9050 Base Rear View

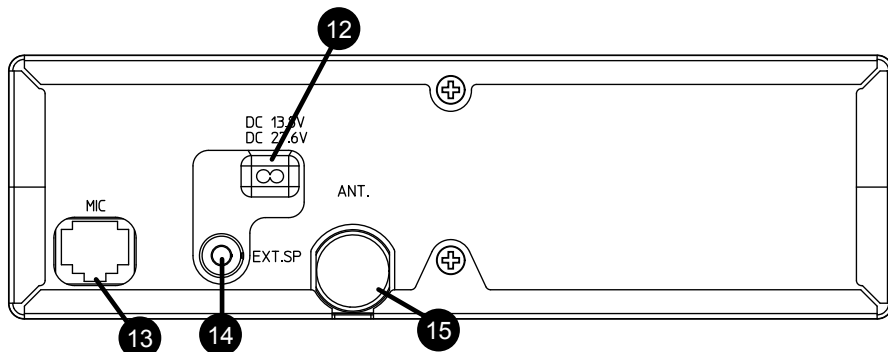

Connectors

- 12 Power Input Connection
- 13 Rear MIC Jack
- 14 External Speaker Jack
- 15 UHF Antenna Connection

Controls & Connectors

Heavy Duty Speaker MIC

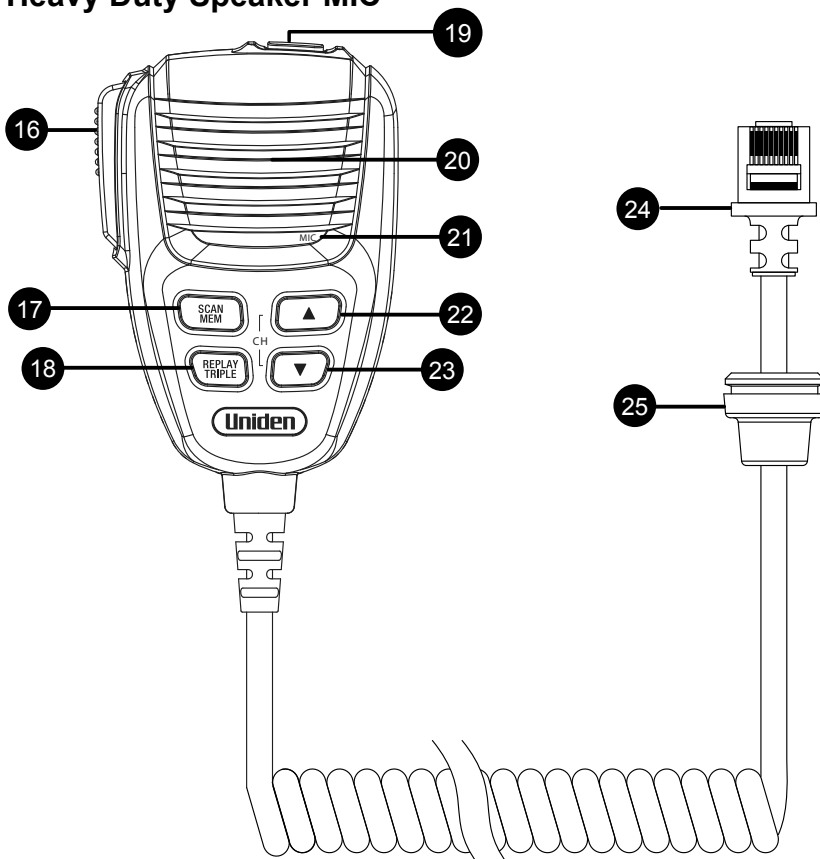

Controls and Connectors

16 PTT - Push To Talk Button

17 **SCAN/MEM** - Scan Button/Memory Button

18 **REPLAY/TRIPLE** - Replay Button/Triple Watch Button

19 **SMART** - Multiple Function

20 **SPEAKER**

21 **MICROPHONE**

22  - Channel Up Button/Select Up Button

23  - Channel Down Button/Select Down Button

24 **RJ45** type plug

25 **Front MIC Jack Rubber Collar**

Controls & Connectors

Remote LCD Speaker MIC (Optional)

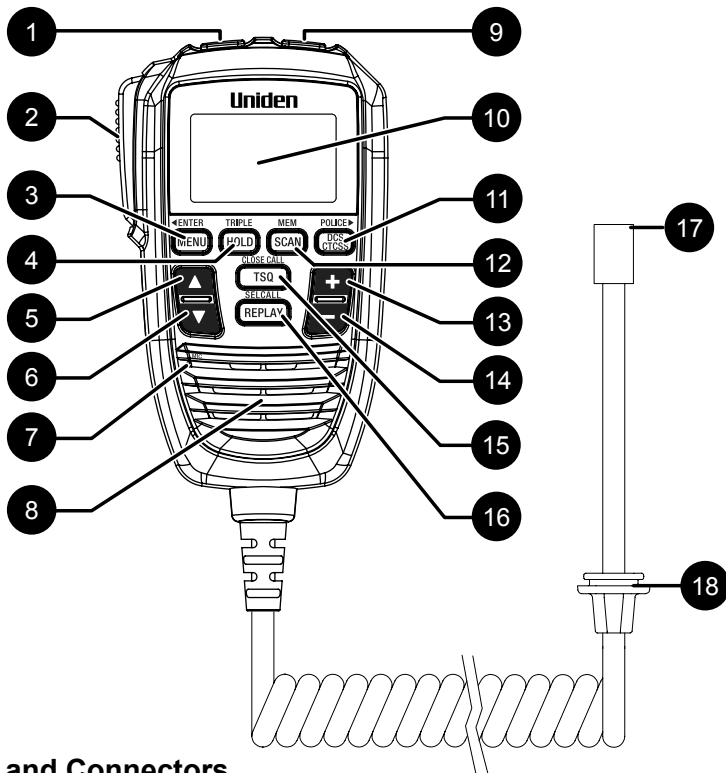

Controls and Connectors

- | | |
|--|---|
| 1 POWER - Power Button | 10 Liquid Crystal Display (LCD) |
| 2 PTT - Push To Talk Button | 11 DCS/CTCSS - DCS & CTCSS Button
/POLICE - Police/CB/Fire Button
▶ - Move selection right |
| 3 MENU - Menu Button/
/ENTER - Enter Button
◀ - Move selection left | 12 SCAN - Scan Button
/MEM - Memory Button |
| 4 HOLD - Hold Button
/TRIPLE - Triple Watch Button | 13 + - Volume Up Button |
| 5 ▲ - Channel Up Button/Select
Up Button | 14 ▬ - Volume Down Button |
| 6 ▼ - Channel Down Button/
Select Down Button | 15 TSQ - Tone Squelch Channel
/Close Call - (Not Available) |
| 7 MICROPHONE | 16 REPLAY - Replay Button
/SELCALL - Selective Calling Button |
| 8 SPEAKER | 17 RJ45 type plug |
| 9 SMART - Multiple Function | 18 Front MIC Jack Cover |

Indicators

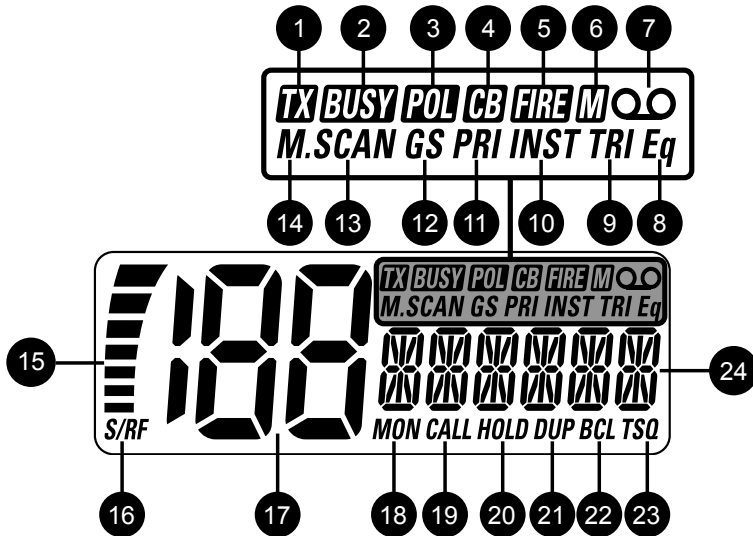

- | | |
|---|---|
| <ul style="list-style-type: none"> 1 TX - Transmit 2 BUSY - Busy 3 POL - Police Bank 4 CB - UHF CB + Extra RX Channel Bank 5 FIRE - Fire (+ Ambulance) Bank 6 M - Channel in Memory 7 OO - Replay Function is enabled 8 Eq - Equalizer 9 TRI - Triple Watch 10 INST - Instant Channel 11 PRI - Priority Channel Watch 12 GS - Group Scan/Master Scan 13 SCAN - Scan 14 M. - MASTER Scan | <ul style="list-style-type: none"> 15 Signal Power Level 16 S/RF- Receive Signal or Transmit 17 100 Channel Indication / Menu Item Setting 18 MON - Monitor 19 CALL - Call Tone & Selcall History 20 HOLD - Hold 21 DUP - Duplex Channel 22 BCL - Busy Channel Lockout 23 TSQ - Tone Squelch enabled 24  - Information Indicator
- (Menu Item/ Code Number / Alpha tag etc.) |
|---|---|

Included with your UH9050 Transceiver

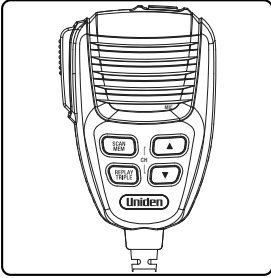

Heavy Duty Speaker
Microphone
(MK-950)

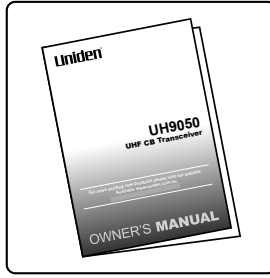

Owner's Manual

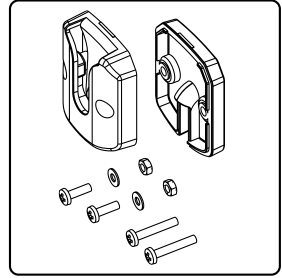

Microphone Hanger with
screws, washers

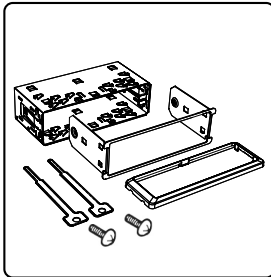

Din Mount Sleeve,
Front Frame Bracket,
Removal Key,
Bezel & Screws

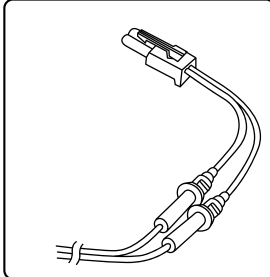

DC Power Cord
with fuse

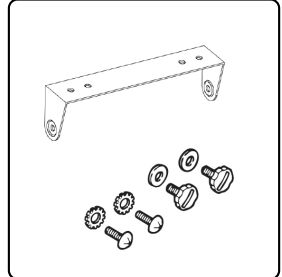

Mounting Bracket
Mounting Screws
Washer Starts and Screws

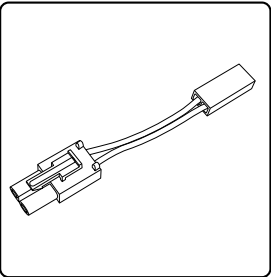

Adaptor Cable

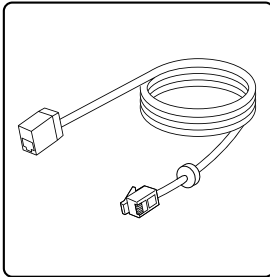

Extension Cable
(EC770)

Optional Accessories



Remote LCD Speaker
Microphone
(RM-980)

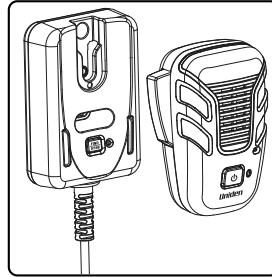

DECT Wireless
Speaker Microphone
(MK-800W)

- UHF Antenna
- External Speaker

Visit the UH9050 page on the website for more information on the availability of optional accessories:

www.uniden.com.au for Australia

DIN Installation

Mounting Using the DIN Bracket

If you are unsure about how to install your UH9050 in your vehicle using the DIN bracket, consult your automobile manufacturer, dealer, or a qualified installer. The DIN bracket is made up of a sleeve and a frame.

Before installing, confirm that your UH9050 fits in the desired mounting area and you have all the necessary materials to complete the task.

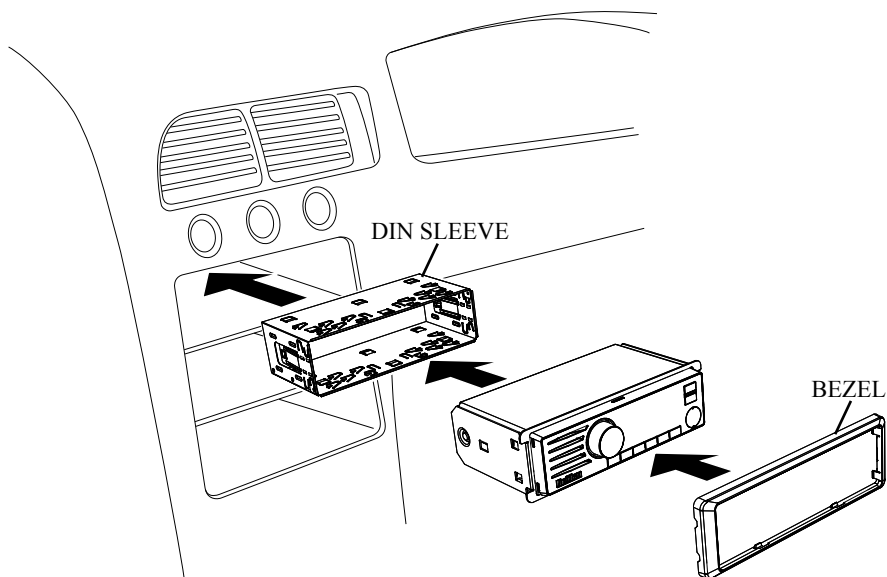
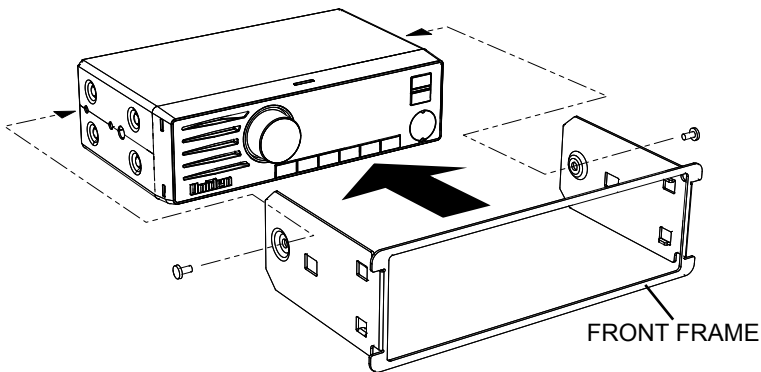

DIN Installation

Installing the DIN Bracket

1. Remove the front frame if previously attached.
2. Install the DIN sleeve into the DIN slot of your dashboard and secure it by bending the top and bottom folding tabs.
3. Slide the front frame into the UH9050. Ensure the threaded holes on UH9050 line up with holes on the front frame.
4. Secure UH9050 onto the side of the front frame using 2 pieces of 6mm screws.
5. Attach the DC power leads to UH9050 and your vehicle. RED goes to a positive (+) connection on your fuse block while BLACK connects to the vehicle chassis ground (-).
6. Attach the antenna cable, rear MIC and rear speaker to the back of UH9050 if using.
7. Make sure all the connections are routed away from any potentially pinching or slicing sheet metal.
8. Slowly slide the front frame (with UH9050 attached and all cable connections done) into the DIN sleeve until it locks in place.
9. Install the bezel on the radio.



If you plan to use the Rear MIC Jack or connect an external speaker at a later time, expect to remove the unit for ease of making those connections.

DIN Installation

Removing the UH9050 from the DIN Sleeve

If you plan to use the Rear MIC Jack at a later time, you should plan to remove the UH9050 from the DIN sleeve. This is easily done using the provided Removal Keys.

Remove the Bezel before fully insert both Removal Keys straight into the slots on the left and the right edges of the radio's dress panel. You cannot remove the radio if only one key is available.

Press in fully and the radio will unlock from the sleeve making withdrawal from the sleeve possible. Store the keys in a safe place for future use.

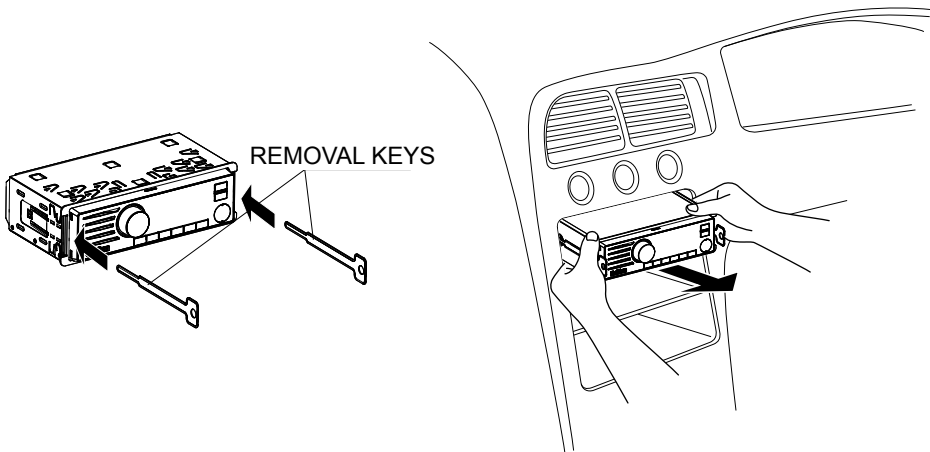

Connecting the Microphone

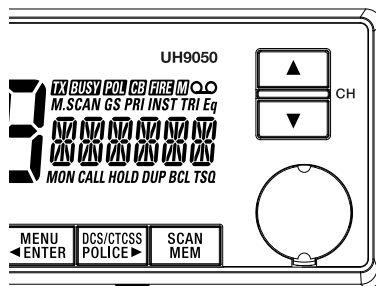
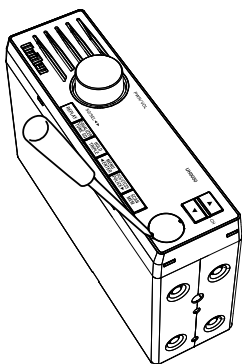

Front MIC Jack

Remove the MIC cover using a flat blade screwdriver. Push the MIC plug at the end of the microphone into the MIC jack until the connection locks into place. Gently tug the MIC cord to test that the connection is locked. Use the Front MIC Jack threaded rubber collar to seal the MIC jack entry from dust.

Disconnecting the MIC from the Front MIC Jack

Pull away the threaded rubber collar and move it down along the cord. Using the flat blade of a screwdriver or similar object carefully press the lock tab at the bottom of the MIC plug and push it upwards. At the same time tug on the MIC cord to draw back the MIC plug.

Rear MIC Jack

Use the Rear MIC Jack if the main base is mounted where a front MIC connection is intrusive or if you wish to use the Remote LCD Speaker MIC with an optional extension cable.

Peel the dust cover from the rear MIC jack. Push the MIC plug at the end of the microphone into the MIC jack until the connection locks into place. An optional 2m extension cable kit is available to enable mounting the main base in a hidden location.



The unit will not function if connected to two Remote LCD Microphones (optional RM-980) at the same time.

Mounting the MIC Hanger

The Microphone Hanger comes in two parts. How and where you mount the MIC hanger will determine which parts to use.

Conventional Mounting with Screws

Use the front part of the MIC Hanger only.

Locate a suitable mounting position and mark and drill two 3mm holes.

Fix the MIC Hanger into place with screws.

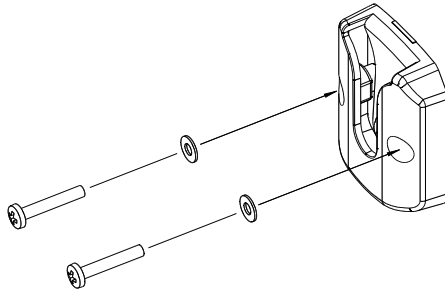

Conventional Mounting with Double Sided Tape (not supplied)

High quality Double-Sided tape can be found at good retail stores.

Secure the front and back pieces of the MIC Hanger using the supplied binding screws.

Locate a suitable mounting position.

Apply high quality Double-Sided tape onto the flat area of the MIC Hanger back piece and then press firmly to the mounting position.

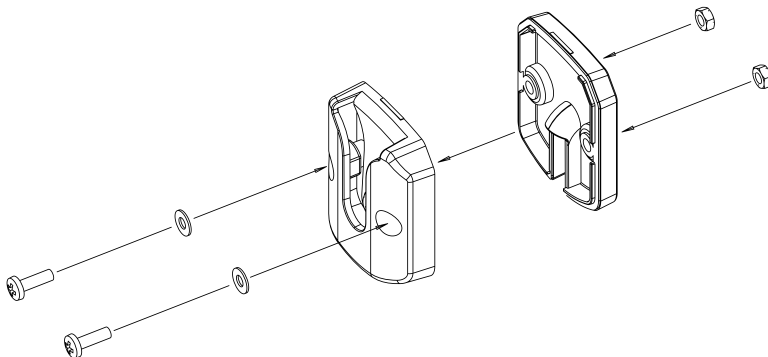

Mounting the MIC Hanger

MIC Hanger mounted over MIC Cable



The curly cord of the Remote LCD Speaker MIC can extend up to 2m. For practical installation of the MIC Hanger mounted over MIC Cable use this method with the Extension Cable.

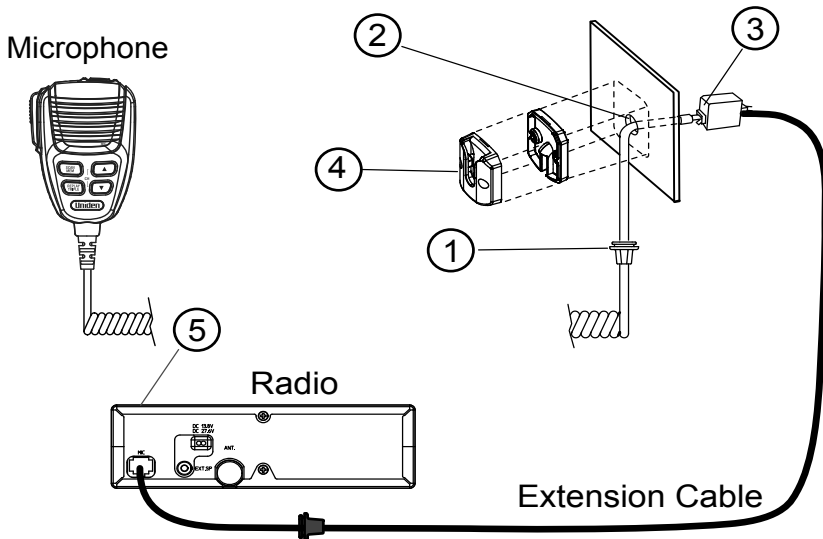

The plug of the extension cable connects to the Radio. The socket end of the extension cable connects with the microphone plug.

1. The rubber collar (dust cover) on the microphone cable is not required and can be cut away or pushed out of the way along the cable.
2. Drill a 13mm hole at the MIC hanger location.
3. Thread the microphone plug through the hole and connect with the extension cable.
4. Mount the MIC Hanger over the hole and cable.
5. At the Radio: Connect the extension cable plug to the MIC Jack. Fit the rubber bushing over the MIC jack.

Operation

Turning on the Power

Press and hold **PWR/VOL** control at the base or the **[POWER]** button on the optional Remote SPK/MIC.

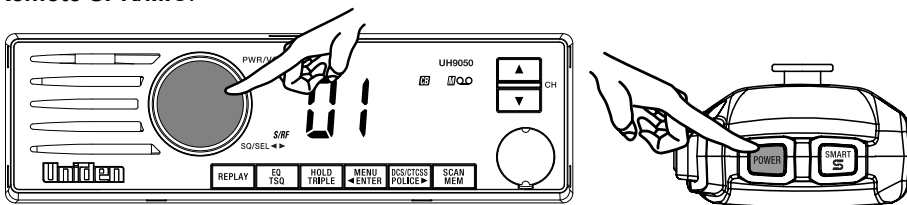

Low-Voltage/High-Voltage Alert

The UH9050 can operate on 12VDC (13.8V) or 24VDC (27.6V) power supply, with the range between 10.2VDC to 28.8VDC.



NOTE

If the power supply voltage exceeds 28.8VDC, an alert tone sounds and **HI DC** flashes for 5 seconds. The power source must not exceed 32VDC otherwise permanent damage may occur to your radio, which may not be covered by the manufacturer's warranty.

If the input voltage falls below 10.2VDC, **LO DC** flashes for 5 seconds. The power turns off automatically if voltage falls below 9.0VDC.

Switch your UH9050 OFF and disconnect it from the power source, before locating the cause of the power supply problem.

Operation

Setting the Volume

Turn the Rotary **PWR/VOL** at the base or press the volume **+ / -** on the optional Remote SPK/MIC to adjust the volume. The volume is composed off + 42 steps.

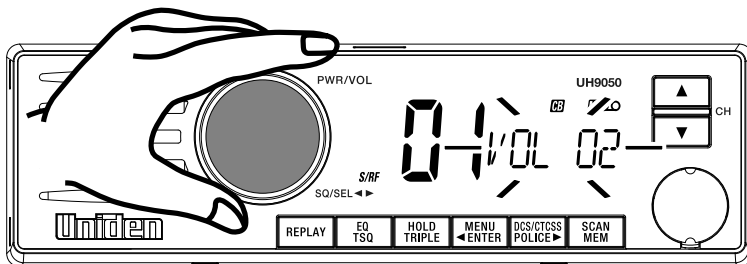

Transmitting

The UH9050 transmits only on UHF-CB Channels.



For your reference a list of the available channels, corresponding frequencies and guidelines for their use and selection is printed on p.52 - p.58. For Australia, Channels 05 and 35 are reserved for Emergency Calls.

Select the desired channel. Press **[PTT]** on the side of the MIC and speak normally into the microphone. Hold it approx. 7cm from your mouth. Release **[PTT]** to end the transmission and listen for a reply.

Smart-Key Function

The smart key **[S]** provides one touch access to one of these functions; Instant Channel, Call Tone, Equalizer or Selcall.

Press and hold **[S]** to change the **SMART** key function between the four options.

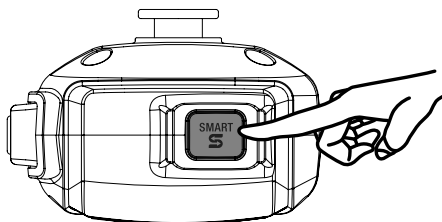

Operation

Voice Enhancer (EQL) Setting

Choose from 4 different receive audio level settings to provide a natural Voice Enhancer for super clarity and performance.

Press **EQL** at the base or using Smart-Key function **[S]** on the MIC when in SMART key EQL mode, to change the setting between;

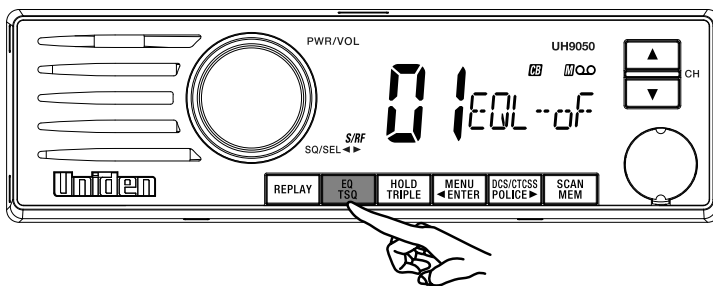

- OFF : Normal - Standard of FLAT.
- L1 : Bass - Enhancing the low frequency, the sound quality becomes mild and easy to listening, not causing fatigue.
- L2 : Midrange - Enhancing midrange frequency, the sound quality becomes clear.
- L3 : High - Enhancing the high frequency, the sound quality becomes sharp.

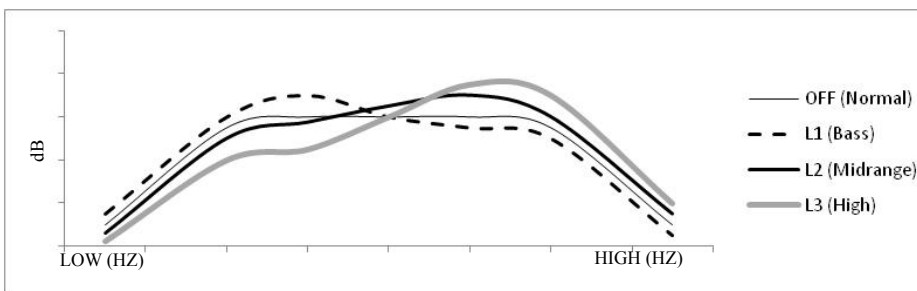

Operation

TRIPLE Watch

Triple watch will continuously monitor the two Instant channel and the current channel for activity (see Programming the Instant Priority Channel, p.27).

Press and hold **[TRIPLE]**. **TRI** icon appears and two beeps will sound.
To cancel Triple Watch press and hold **[TRIPLE]**. **TRI** icon disappears.

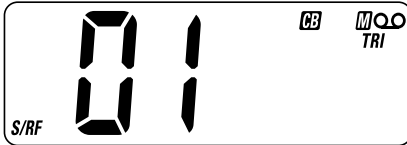

NOTE

- Every 1.5 seconds the Instant channel is monitored for 100msec.
- Triple watch function stops temporarily when receiving a signal.
- Triple watch function is invalid in Scan mode.

Operation

Selecting a Channel

Press  /  on the base or the MIC to select the desired channel.

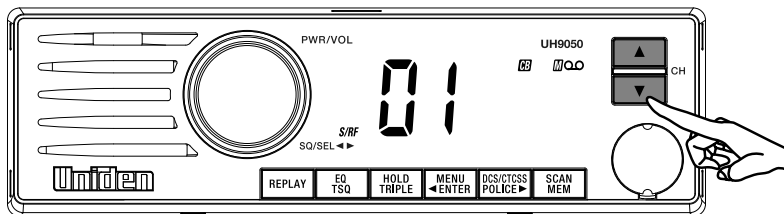

Channel Banks - Using the POLICE Button

The UH9050 has three banks (groups) of channels to select from;

- CB** UHF CB + User programmable RX channels¹
- POL** Pre-programmed Police frequencies²
- FIRE** Pre-programmed Fire & Ambulance frequencies²

When the **CB** icon is showing the 80 UHF-CB and any user programmed RX channels will be available for selection or scanning. The 80 UHF-CB channels are numbered 01-80. The user programmable RX channels are numbered 81-180 and only show, in the DCS/CTCSS code area, when programmed.

When the **POL** icon is showing then pre-programmed police channels will be available. When the **FIRE** icon is showing then pre-programmed fire & ambulance channels will be available. The police, fire & ambulance frequencies have channel numbers.

1. Press and hold [**POLICE**] to select the desired channel bank(s) combination.
The channel banks can be selected as follows;

----	CB	----
POL	----	----
----	----	FIRE
POL	----	FIRE
POL	CB	----
----	CB	FIRE
POL	CB	FIRE



¹ Available frequencies & channels are within 400-520MHz Band only in 12.5kHz steps.

² Police, Fire & Ambulance reception is unencrypted analogue.

For your reference a list of the available channels, corresponding frequencies and guidelines for their use is printed on p.52 - p.58. For Australia, Channels 05 and 35 are reserved for Emergency Calls.

Operation

CTCSS (Continuous Tone Coded Squelch System)

Use the CTCSS or DCS privacy codes to talk to UHF-CB users, who are using the same code, without hearing other users on the same channel.

When a CTCSS or DCS tone is set for a UHF-CB channel, the CTCSS or DCS tone is displayed in the DCS/CTCSS code area. For channels with the setting of CTCSS OFF, there will be no display in the DCS/CTCSS code area.



NOTE

CTCSS and DCS is not available on CH 05 and CH 35. For your reference a list of the available channels, corresponding frequencies and guidelines for their use and selection is printed on p.52 - p.58. For Australia, Channels 05 and 35 are reserved for Emergency Calls.

Press / to select the desired channel to use CTCSS.

Press **[DCS/CTCSS]** on the base. **OFF** icon flashes.

Press / channel selector or turn the rotary **PWR/VOL** at the base to select the desired CTCSS code 01 - 38.

Press **[DCS/CTCSS]** once to store the new setting.

To turn off CTCSS (or DCS) select the **oFF** code during setting.

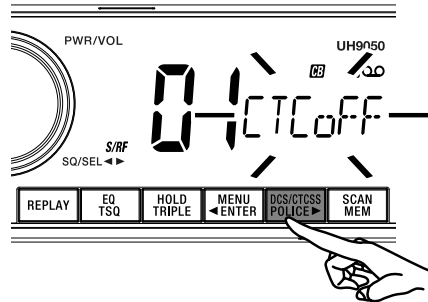

DCS (Digital Coded Squelch)

DCS is a digital extension of CTCSS. It provides 104 extra, digitally coded, squelch codes that follow after the 38 CTCSS codes. CTCSS 1-38, followed by DCS 1-104.

Follow the steps for setting a CTCSS code.

Press **[DCS/CTCSS]** to set. The DCS and code will display.

Operation

Using Repeater Channels

UHF CB repeaters are used to retransmit or relay your signal. Repeaters will extend the range of your radio and overcome the shielding effect caused by solid obstructions. In normal Simplex operation, your radio transmits on one particular frequency and receives on that same frequency.

If there is a barrier that partially blocks your transmitted signal, the probability of another radio receiving the signal is very slim. Hills, tall buildings, metallic structures,...etc tend to act as a screen between radios.

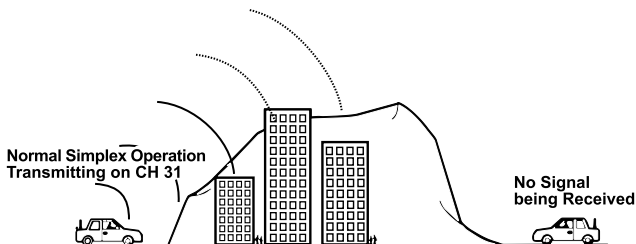

Standard Operation without the aid of a Repeater station.

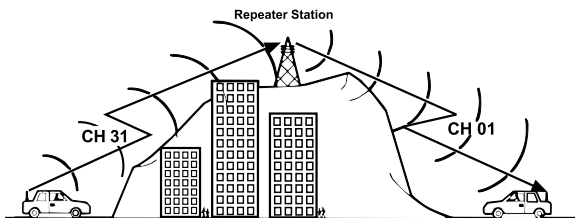

Operation with the aid of a Repeater Station (Duplex).

The signal coming from your radio is received by the Repeater Station and the re-transmitted at the same time on another channel. This operation is called "Duplexing".

For example,

CH01 on Duplex Mode will Receive on CH01 but Transmit on CH31

CH02 on Duplex Mode will Receive on CH02 but Transmit on CH32 etc...



If you transmit on CH01 Duplex mode, you are actually transmitting on CH31 the repeater station down-converts your signal and retransmits on CH01.

Operation

Setting the Squelch Level

The Squelch feature has 5 preset squelch levels:

- SQL-0** - Squelch open
- SQL-1** - maximum sensitivity (minimum squelch)
- SQL-2** - moderate sensitivity
- SQL-3** - medium sensitivity
- SQL-4** - minimum sensitivity (max/tight squelch)

1. Press Rotary **SQ/SEL**.
2. Press  /  channel selector or turn the Rotary **SQ/SEL** at the base to change the setting between 0, 1, 2, 3 or 4.
3. Press the Rotary **SQ/SEL** to save the setting.

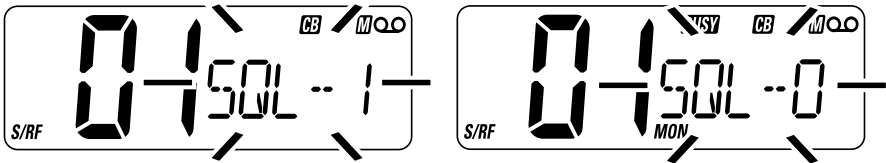

NOTE

- Selecting tight squelch mode may prevent the reception of weak signals.
- High noise areas may still break the squelch.

Operation

Operating the UHF CB Radio in Duplex Mode

For this example we are adopting CH01 as the channel being used in your area for repeater use.

1. Press **[MENU]**.
2. Press **▲** / **▼** channel selector or turn the Rotary **PWR/VOL** or at the base till **DUPLEX** display on the screen. Press the Rotary **PWR/VOL** or **[MENU]** to confirm selection.
3. Turn the Rotary **PWR/VOL** or press **▲** / **▼** channel selector at the base to change the setting between **ON** or **OFF** (standard channel number).
4. Press **[MENU]** the Rotary **PWR/VOL** to save the setting.
5. Press Rotary **PWR/VOL** or press and hold **[MENU]** to exit menu mode.

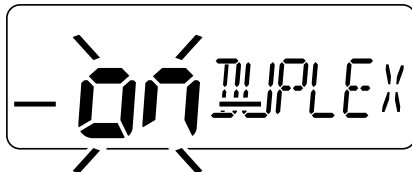

DUP icon displays when a selected channel is set to Duplex mode.



- Only channels 01 - 08, and channels 41 - 48 are available for Duplex.
- Check with your local Retailer for information on available repeaters.
- If a button is not pressed within 10 seconds the UHF CB Radio will automatically exit the Menu Mode.

Priority Watch

To switch Priority Watch On/Off;

1. Press **[MENU]** on the base.
2. Turn the Rotary **PWR/VOL** or press **▲** / **▼** channel selector at the base till **PRI-W** display on the screen. Press the Rotary **PWR/VOL** or **[MENU]** to confirm selection.
3. Turn the Rotary **PWR/VOL** or press **▲** / **▼** channel selector to change the setting between **ON** or **OFF**.
4. Press the Rotary **PWR/VOL** or **[MENU]** to save the setting.
5. Press Rotary **PWR/VOL** or press and hold **[MENU]** to exit menu mode.

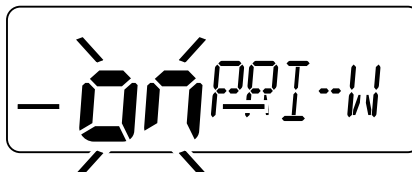

If SCAN is deactivated while it is tuned to an active channel, the UH9050 will stay on that active channel. If none of the channels are active, the UH9050 will reinstate the scan start channel.



If OS/GS Scanning is initiated when there are no channels programmed in OS/GS memory, an error tone will be heard and scanning will not start (see Add/Remove Channels from SCAN Memory, p.28).

Operation

Programming the Instant Priority Channel-1

1. Press **[MENU]**.
2. Press **▲** / **▼** channel selector or turn the Rotary **PWR/VOL** at the base till **P-CH1** display on the screen. Press the **[MENU]** or Rotary **PWR/VOL** to confirm selection.
3. Press **▲** / **▼** channel selector or turn the Rotary **PWR/VOL** at the base to select the desired channel.
4. Press **[MENU]** or Rotary **PWR/VOL** to save the setting.
5. Press Rotary **PWR/VOL** or press and hold **[MENU]** to exit menu mode.

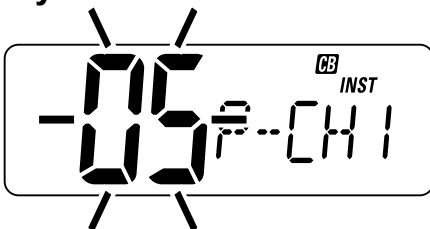

Programming the Instant Priority Channel-2

1. Press **[MENU]**.
2. Press **▲** / **▼** channel selector or turn the Rotary **PWR/VOL** at the base till **P-CH2** display on the screen. Press the **[MENU]** or Rotary **PWR/VOL** to confirm selection.
3. Press **▲** / **▼** channel selector or turn the Rotary **PWR/VOL** at the base to select the desired channel.
4. Press **[MENU]** or Rotary **PWR/VOL** to save the setting.
5. Press Rotary **PWR/VOL** or press and hold **[MENU]** to exit menu mode.

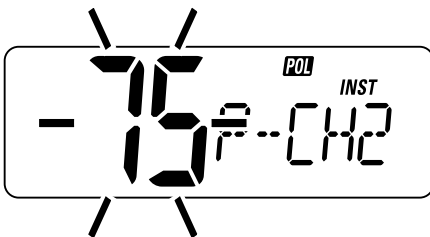

Recalling the Instant Channel

Press **[S]** when Smart Key is set to Instant Channel function.

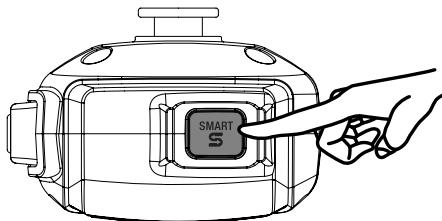

Operation

Scanning

The UH9050' Scanning feature allows you to search for active channels automatically. There are 3 scanning modes;

Open Scan (OS),

Group Scan (GS) and

Master Scan (M.SCN) (a special case of Group Scan).



During SCAN the UH9050 only checks channels or frequencies that are in the SCAN Memory, which are indicated by the **M** (memory) icon. The UH9050 maintains two SCAN Memories; one for Open Scan (OS) mode and the other for Group Scan (GS) mode, to give you flexibility and allow you to use the radio more effectively.



NOTE

Group Scan and Master Scan modes share the same SCAN Memory.

Furthermore, any combination of the three channel groups can be scanned by press and hold **[POLICE]** during scan to select the desired channel groups.

1. Press **[SCAN]** to start Scanning.
2. The SCAN icon appears and flashing.
3. The scan direction can be changed at any time by pressing  /  channel selector.
4. Press **[SCAN]** to stop Scanning.

Add/Remove Channels from SCAN Memory

Select OS/GS Scanning Mode. Select the channel you want to store.

Press and hold **[MEM]**. **M** icon appears and two beep tones sound.

To remove the channel from SCAN memory, press and hold **[MEM]** once more. The **M** icon disappears.

Operation

Open Scan (OS) Mode

Open Scan is the default scan mode.

All UHF-CB, user-programmed extra RX channels, Police and Fire & Ambulance frequencies have been added to the OS SCAN Memory for convenience. To add/remove channels from OS SCAN Memory, refer to p.28.

Allows continuous scanning of all selected channels. If an active channel is found, scanning will stop on that channel. If the received signal ceases, the unit will wait 3 seconds for the signal to return, otherwise scanning resumes.

After transmission in scan mode, the unit will wait 20 seconds for the signal to return, otherwise scanning resumes.

To deactivate SCAN, press **[SCAN]**.



NOTE

If SCAN is deactivated while on an active channel, the UH9050 will stay on that active channel. If no channels are active, the UH9050 will reinstate the starting channel.



NOTE

OS Mode is indicated by the absence of the GS icon.

Operation

Group Scan (GS) Mode

GS Mode has CH09 to CH20 in the SCAN Memory by default. Channels must be stored to the GS SCAN Memory before group scan can start. To add/remove channels from GS SCAN Memory, refer to p.28.





Includes the accessory feature Priority Watch which allows you to monitor the Instant Priority Channel while scanning (see p.27 for setting Instant Priority Channel and p.26 to turn on Priority Watch).

GS Scanning checks the Instant Priority Channel for activity regularly when Priority Watch is ON.

If the Priority Channel becomes active the radio will stay on that channel for as long as the signal is present. If the received signal ceases, Priority Scanning continues after 3 seconds.

If scanning stops on a channel which is not a Priority Channel, UHF CB Radio will continue monitoring the Priority Channel for activity while listening to the active one.

To select GS Scan Mode:

1. Press **[MENU]**.
2. Press  /  channel selector or turn the Rotary **PWR/VOL** at the base till **SCAN** display on the screen. Press the **[MENU]** or Rotary **PWR/VOL** to confirm selection.
3. Press  /  channel selector or turn the Rotary **PWR/VOL** at the base to select **GROUP**.
4. Press **[MENU]** or Rotary **PWR/VOL** to save the setting.
5. Press Rotary **PWR/VOL** or press and hold **[MENU]** to exit menu mode.

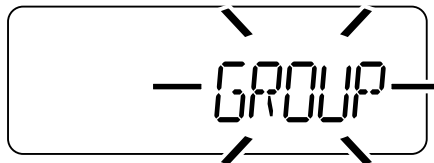

If a button is not pressed within 10 seconds the UHF CB Radio will automatically exit the Menu Mode.

Operation

Master Scan Mode

MASTER SCAN allows continual communication across congested channels.

Master Scan scans channels stored into GS Memory and only opens the squelch for signals with the correct subcode (CTCSS or DCS tone).

To achieve this, all radios in your group must have the same channels in GS memory (group channels) and use the same Subcode (CTCSS or DCS tone).

By scanning only group channels, radios in the network will be able to detect and receive group transmissions- continual communication without interruption. When transmitting in this mode, the radio switches to an unused group channel if it detects another signal with no code, or the wrong code, on the channel last used by the group. In this way, all group users will be able to have continual communication to or from other users.

CH09-CH20 are stored into GS Memory and CTCSS01 is set for MASTER SCAN Subcode by default. The GS memory can be changed, channel by channel, if desired - but for Master Scan to work effectively each radio in the group must have the same channels in its GS memory.

To add/remove channels from GS SCAN Memory, refer the section above.



NOTE

RX only Channels (CH22, CH23, CH61, CH62 and CH63), User Programmable RX Channels (CH81 to CH180) and Police or Fire (& Ambulance) channels group will not be included in MASTER SCAN Mode even though stored into GS Memory Also channels for which Duplex Setting are On will be skipped in MASTER SCAN Mode.

Operation

To select MASTER SCAN Mode:

1. Press **[MENU]**.
2. Press the **[MENU]** or Rotary **PWR/VOL** to confirm selection.
3. Press **▲**/**▼** channel selector or turn the Rotary **PWR/VOL** at the base till **Scan** display on the screen. Press the **[MENU]** or Rotary **PWR/VOL** to confirm selection.
4. Press **▲**/**▼** channel selector or turn the Rotary **PWR/VOL** to select desired preset GS memory group. Press the **[MENU]** or Rotary **PWR/VOL** to confirm selection.



MASTER



PREST 1

:



PREST 4

MASTER: Master Scan is ON with the current GS channel memory. Open/Group Scan is disabled.

PREST1: Master Scan is ON with loading CH09-20 in GS.

PREST2: Master Scan is ON with loading CH21-30, 39, 40 in GS.

PREST3: Master Scan is ON with loading CH49-60 in GS.

PREST4: Master Scan is ON with loading CH61-70, 79, 80 in GS.

5. Press **▲**/**▼** channel selector or turn the Rotary **PWR/VOL** at the base to select desired CTCSS code 01 - 38 or DCS code 01 - 104.

CTCSS:

DCS:

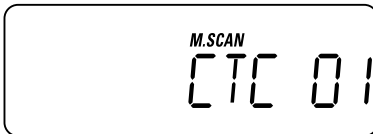

M.SCAN
CTC 01

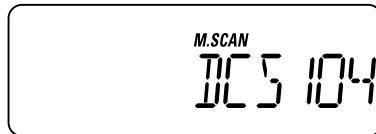

M.SCAN
DCS 104

6. Press the Rotary **PWR/VOL** or **[MENU]** to save the setting.
7. Press Rotary **PWR/VOL** or press and hold **[MENU]** to exit menu mode.



If a button is not pressed within 10 seconds the UHF CB Radio will automatically exit the Menu Mode.

Operation

Selecting the Call Tone (Wake Up Tone)

1. Press **[MENU]**.
2. Press **▲** / **▼** channel selector or turn the Rotary **PWR/VOL** at the base till **C-TONE** display on the screen. Press the **[MENU]** or Rotary **PWR/VOL** to confirm selection.
3. Press **▲** / **▼** channel selector or turn the Rotary **PWR/VOL** at the base to change the setting between **1, 2, 3... 10**.
4. Press **[MENU]** or Rotary **PWR/VOL** to save the setting.
5. Press Rotary **PWR/VOL** or press and hold **[MENU]** to exit menu mode.

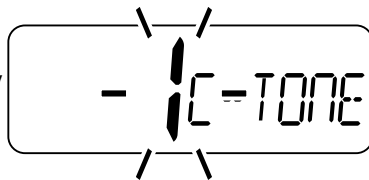

If a button is not pressed within 10 seconds the UHF CB Radio will automatically exit the Menu Mode.

Busy Channel Lockout

If the channel is already in use, you can prevent the UHF CB Radio from transmitting. This is particularly important when using CTCSS/DCS.

1. Press **[MENU]**.
2. Press **▲** / **▼** channel selector or turn the Rotary **PWR/VOL** at the base till **BCL** display on the screen. Press the **[MENU]** or Rotary **PWR/VOL** to confirm selection.
3. Press **▲** / **▼** channel selector or turn the Rotary **PWR/VOL** at the base to change the setting between **ON** or **OFF**.
4. Press **[MENU]** or Rotary **PWR/VOL** to save the setting.
5. Press Rotary **PWR/VOL** or press and hold **[MENU]** to exit menu mode.

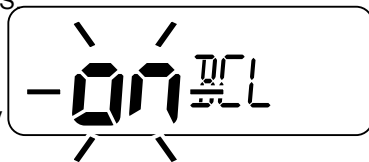

If a button is not pressed within 10 seconds the UH9050 will automatically exit the Menu Mode.

Operation

Roger Beep

1. Press **[MENU]**.
2. Press **▲** / **▼** channel selector or turn the Rotary **PWR/VOL** at the base till **ROGER** display on the screen. Press the **[MENU]** or Rotary **PWR/VOL** to confirm selection.
3. Press **▲** / **▼** channel selector or turn the Rotary **PWR/VOL** at the base to change the setting between **ON** or **OFF**.
4. Press **[MENU]** or Rotary **PWR/VOL** to save the setting.
5. Press Rotary **PWR/VOL** or press and hold **[MENU]** to exit menu mode.



If a button is not pressed within 10 seconds the UH9050 will automatically exit the Menu Mode.

Key Beep

1. Press **[MENU]**.
2. Press **▲** / **▼** channel selector or turn the Rotary **PWR/VOL** at the base till **BEEP** display on the screen. Press the **[MENU]** or Rotary **PWR/VOL** to confirm selection.
3. Press **▲** / **▼** channel selector or turn the Rotary **PWR/VOL** at the base to change the setting between **OFF**, **1**, **2**, **3**... **7**.
4. Press **[MENU]** or Rotary **PWR/VOL** to save the setting.
5. Press Rotary **PWR/VOL** or press and hold **[MENU]** to exit menu mode.

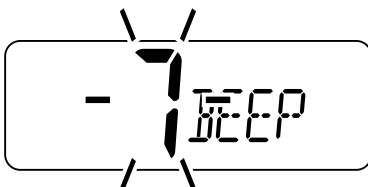

If a button is not pressed within 10 seconds the UHF CB Radio will automatically exit the Menu Mode.

Operation

Alpha Tag

The SELCALL IDs and Extra Receive Channels have the option of displaying a name (Alpha Tag) instead of the ID or frequency. Set Alpha Tag to ON to display the name if it has been programmed.

1. Press **[MENU]**.

2. Press **▲** / **▼** channel selector or turn the Rotary **PWR/VOL** at the base till **ALPHA** display on the screen. Press the **[MENU]** or Rotary **PWR/VOL** to confirm selection.



3. Press **▲** / **▼** channel selector or turn the Rotary **PWR/VOL** at the base to change the setting between **ON** or **OFF**.

4. Press **[MENU]** or Rotary **PWR/VOL** to save the setting.

5. Press Rotary **PWR/VOL** or press and hold **[MENU]** to exit menu mode.

Internal Speaker

Use this to set which speaker ON.

Set **1 SP ALL** to switch both base unit and microphone speaker on.

Set **2 SP MAI** to switch base unit speaker on only.

Set **3 SP MIC** to switch microphone speaker on only.

1. Press **[MENU]**.

2. Press **▲** / **▼** channel selector or turn the Rotary **PWR/VOL** at the base till **SP** display on the screen. Press the **[MENU]** or Rotary **PWR/VOL** to confirm selection.

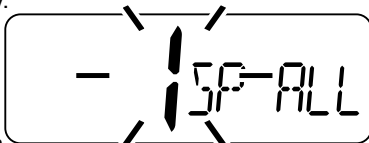

3. Press **▲** / **▼** channel selector or turn the Rotary **PWR/VOL** at the base to change the setting between **1**, **2** or **3**.

4. Press **[MENU]** or Rotary **PWR/VOL** to save the setting.





5. Press Rotary **PWR/VOL** or press and hold **[MENU]** to exit menu mode.



- When the MIC is not connected, there is no option 3 SP MIC.
- The base will turn on the base unit speaker when MIC is removed from the base unit even though the setting was set to 3 SP MIC.

Operation

Backlight Colour



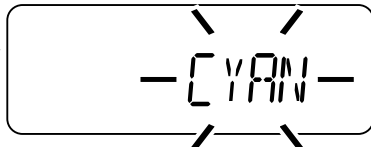

1. Press **[MENU]**.
2. Press  /  channel selector or turn the Rotary **PWR/VOL** at the base till the current Backlight colour **[CLEAR, BLUE, RED, ORANGE, GREEN, CYAN or YELLOW]** display on the screen. Press the Rotary **PWR/VOL** or **[MENU]** to confirm selection.
3. Press  /  channel selector or turn the Rotary **PWR/VOL** at the base to change the desired colour setting.
4. Press **[MENU]** or Rotary **PWR/VOL** to save the setting.
5. Press Rotary **PWR/VOL** or press and hold **[MENU]** to exit menu mode.



NOTE

If a button is not pressed within 10 seconds the UHF CB Radio will automatically exit the Menu Mode.

Backlight Level

1. Press **[MENU]**.
2. Press  /  channel selector or turn the Rotary **PWR/VOL** at the base till the **LIGHT** display on the screen. Press the Rotary **PWR/VOL** or **[MENU]** to confirm selection.
3. Press  /  channel selector or turn the Rotary **PWR/VOL** at the base to change the setting between **01, 02, or 03**.
4. Press **[MENU]** or Rotary **PWR/VOL** to save the setting.
5. Press Rotary **PWR/VOL** or press and hold **[MENU]** to exit menu mode.



NOTE

If a button is not pressed within 10 seconds the UHF CB Radio will automatically exit the Menu Mode.

Operation

MIC Contrast Level (If Optional MIC is connected)

1. Press **[MENU]**.
2. Press **▲** / **▼** channel selector or turn the Rotary **PWR/VOL** at the base till the **MIC-C** display on the screen. Press the Rotary **PWR/VOL** or **[MENU]** to confirm selection.
3. Press **▲** / **▼** channel selector or turn the Rotary **PWR/VOL** at the base to change the setting between **01**, **02**, **03**.... **10**.
4. Press **[MENU]** or Rotary **PWR/VOL** to save the setting.
5. Press Rotary **PWR/VOL** or press and hold **[MENU]** to exit menu mode.

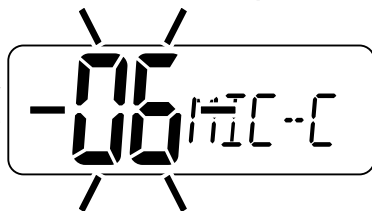

NOTE

- MIC LCD contrast setting will only appear when a RM-980 is connected to the base unit.



NOTE

- If a button is not pressed within 10 seconds the UHF CB Radio will automatically exit the Menu Mode.

Recording Mode (Instant Replay)

1. Press **[MENU]**.
2. Press **▲** / **▼** channel selector or turn the Rotary **PWR/VOL** at the base till the **RECORD** display on the screen. Press the Rotary **PWR/VOL** or **[MENU]** to confirm selection.
3. Press **▲** / **▼** channel selector or turn the Rotary **PWR/VOL** at the base to change the setting between **ON** or **OFF**.
4. Press **[MENU]** or Rotary **PWR/VOL** to save the setting.
5. Press Rotary **PWR/VOL** or press and hold **[MENU]** to exit menu mode.







NOTE

- If a button is not pressed within 10 seconds the UHF CB Radio will automatically exit the Menu Mode.

Operation

Scramble

Scramble enables private communications by scrambling the voice signal. This prevents users without descrambler equipment or a compatible unit understanding the conversation. Select desired channel.

1. Press **[MENU]**.
2. Press  /  channel selector or turn the Rotary **PWR/VOL** at the base till the **SCRMBL** display on the screen. Press the Rotary **PWR/VOL** or **[MENU]** to confirm selection.
3. Press  /  channel selector or turn the Rotary **PWR/VOL** at the base to change the setting between **OFF**, **1** or **2**.
4. Press **[MENU]** or Rotary **PWR/VOL** to save the setting.
5. Press Rotary **PWR/VOL** or press and hold **[MENU]** to exit menu mode.

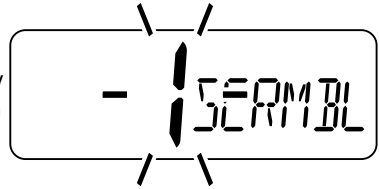

For safety purpose, Scramble is invalid on channel 5, 11, 22, 23 and 35.



If a button is not pressed within 10 seconds the UHF CB Radio will automatically exit the Menu Mode.

Operation - Special Features

100 User Programmable RX Channels

The UH9050 has 100 receive only channels (CH81 to CH180) which can be programmed with frequencies ranging from 400-520MHz (in 12.5kHz steps). The extra RX channels only appear, as part of the CB channel bank, when a frequency has been programmed to a channel. There are two ways to programme RX channels;

1. If you know the frequency you may manually programme it to a channel.
2. Store a Police or Fire (& Ambulance) frequency to a channel.

Furthermore, the RX channels can be Alpha Tagged (given a name) if desired.

Manually Programme a RX Channel

In CB channel mode (UHF CB channel);

1. Press & hold **[MENU]**. The lowest available empty RX channel will flash.
2. Turn the Rotary **PWR/VOL** if you wish to select another RX channel from CH81 - CH180.
3. Press the Rotary **PWR/VOL** to confirm selection and begin the frequency edit. The MHz digit range flashes. Use ◀ or ▶ to shift between MHz range (between 400-520MHz) & kHz range (in 12.5kHz steps).
Turn the Rotary **PWR/VOL** to select the desired frequency within MHz & kHz ranges.
4. When desired frequency is entered press the Rotary **PWR/VOL** to move to Alpha Tag selection. A cursor flashes in the 1st alpha position.
If you do not wish to name the channel then skip this step.
Turn the Rotary **PWR/VOL** to select the desired alpha character.
Use ◀ or ▶ to shift between cursor positions.
5. When finished press the Rotary **PWR/VOL**. A long confirmation tone sounds to indicate the new channel is programmed. The channel flashes to enable selection for programming of next channel if desired.
6. Press and hold **[MENU]** to save the setting and exit programming mode.

Operation - Special Features

Search Extra Channel Range and Programme a RX Channel



UH9050 can search extra channel range (400MHz-520MHz) per 12.5KHz step. Then you can store the stay frequency to extra channel.

In CB channel mode (UHF CB channel);

1. Press & hold **[MENU]**. The lowest available empty RX channel will flash.
2. Turn the Rotary **PWR/VOL** if you wish to select another RX channel from CH81 - CH180.
3. Press **[SCAN]** to start scanning. Turn the Rotary **PWR/VOL** clockwise for ascending order or counterclockwise for descending order.
If an active frequency channel found, scanning will stop on that frequency. To skip, turn the rotary knob to continue scanning.
4. When desired frequency is found, press the Rotary **PWR/VOL** to move to Alpha tag selection. A cursor flashes in the first alpha position.
If you do not wish to name the channel then skip this step.
Turn the Rotary **PWR/VOL** to select the desired alpha character.
Use ◀ or ▶ to shift between cursor positions.
5. When finished, press the Rotary **PWR/VOL**. A long confirmation tone sounds to indicate the new channel is programmed. It will return and stay at the scanned frequency. If no signal, scanning resumes. Press **[SCAN]** to stop scanning.
6. Press and hold **[MENU]** to save the setting and exit programming mode.

Operation - Special Features

Store a Police or Fire frequency to a RX Channel

Select the Police or Fire (& Ambulance) channels group by press and hold **[POLICE]**, and then select a desired frequency by pressing  /  channel selector.

Or during SCAN, when scan stops on a Police or Fire (& Ambulance) frequency which you wish to store press **[HOLD]** to stay on that frequency.

1. Press and hold **[MENU]**. The selected Police and Fire (& Ambulance) frequency programmed to the lowest available empty RX channel. The RX channel will appear and alternating with the selected Police and Fire (& Ambulance) frequency.

Press **[PTT]** on the microphone to exit programming mode and if you do not wish to edit any other setting.

2. Turn the Rotary **PWR/VOL** if you wish to select another RX channel.
3. Press the Rotary **PWR/VOL**. A long confirmation tone sounds to indicate programming the selected channel.

The RX channel number flashes.

4. Press and hold **[MENU]** to save the setting and exit programming mode.

Operation - Special Features

Instant Replay

The Instant Replay feature automatically records up to 1 minute of received signal(s) which can be instantly replayed (through the speaker) by pressing **[REPLAY]**.

Instant Replay automatically records receive signal(s) in the following modes;

- CB & Extra RX channel, Police and Fire (& Ambulance) channel mode
- Scan Mode

Instant Replay does not record when in monitor mode (SQT-0 setting in normal channel mode).

Press **[REPLAY]** on the base unit or Speaker MIC at anytime to;

1. Playback the most recent received signal. OR
2. Playback the most recent recorded signal in the replay buffer (if Instant Replay automatic receive record was turned Off, see Turning Instant Replay On/Off below).

During playback the display shows REPLAY and the number of the currently playing recording.

After the most recent received signal has been played back, a long confirmation tone sounds and the radio returns to the previous mode.

During playback older recordings can be accessed by pressing the **▲** / **▼** channel selector at the base or on the Speaker MIC to skip forward/back between recordings stored within the 1 minute buffer. The record number indicates which discrete recording is currently being replayed.

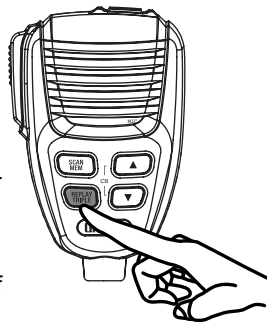

NOTE

- Received signals shorter than 500ms are not recorded.
- Automatic recording of receive signal(s) is temporarily suspended during Instant Replay playback.
- Older recordings are automatically overwritten when new recordings are stored.
- Most received communications are short and the 1 minute buffer may contain several recordings.
- Transmissions (TX) are not recorded.

Operation - Special Features

Turning Instant Replay On/Off

Instant Replay is ON by default. The **OO** icon displays to indicate Instant Replay automatic record is On.

Press and hold **[REPLAY]** to turn Instant Replay On/Off. Two beep tones sound.

Turn Instant Replay Off if you want to prevent the current 1 minute of recordings from being overwritten.

Selective Calling

Selective Calling (Selcall) is a special Sequential Tone Squelch System that allows the user to receive/transmit calls selectively from/to an individual or group, on a shared busy channel. Therefore Selcall is a group feature used by groups with similarly set up radios.

The UH9050 has a Selective Calling system. Exceptional features, like 10 Selcall ID Memories, Receiver Quieting, Tone Squelch Scanning, Tone and Group Calling make the UH9050 superior to other transceivers in its class.

Receiver Quieting (Tone Squelch)

When activated on individual UHF-CB channels (except for emergency CH05 and CH35), it automatically mutes the receiver audio circuit of the radio. It will stay in this Quiet mode as long as the Selcall tone code (Selcall ID) required to open the muting circuit is not received.

Call Alarm

When a received code matches to your Selcall ID, an alarm (CA Alert) will be emitted informing you that a caller is on the channel.

Tone Squelch Scanning

Scans only tone squelched Channels.

Tone Calling

Allows you to selectively call another radio. Up to 10 Selcall IDs can be stored for frequently called radios.

Group Calling Capability

Transmits Group Calls.

Operation - Special Features

Programming the Selcall ID for your UH9050

The radio Selcall ID is the ID other users will identify as being your radio. It is set in the Selcall settings menu as follows:

1. Power Off the UH9050.
2. Press and hold **[POWER]** and **[MENU]**. The UH9050 should turn on in the SELCALL Menu selection state (no tone will sound). **Cd** displays to indicate the Call ID setting (factory default ID is 00000).
3. Press **[SCAN]** to begin the frequency edit. The 5th digit of the ID flashes.
4. Use **◀** or **▶** to shift between digits. A 6th digit (for 6 tone Selcall) is available and indicated by a ' _ '.
5. Turn the Rotary **PWR/VOL** or press **▲** / **▼** channel selector to select the desired ID.
6. Press and hold **[MENU]** to save the setting.
7. Press and hold **[MENU]** again to exit programming mode.
A long confirmation tone sounds.

Storing Selcall IDs of other users to the ID Memory

1. Press **[S]** when Smart Key is set to **SELCALL** function. The Selcall ID memory will open.
2. Turn the Rotary Channel Selector to select the desired memory slot to edit.



NOTE

- Up to 10 ID memories can be stored.
- If you expect to make calls to radios not stored in the ID memory then leave memory ID 1 blank for manual ID entry at the time of the call.

3. Press **[SCAN]** to begin the ID edit. The 5th digit of the ID flashes.
4. Use **◀** or **▶** to shift between digits. A 6th digit (for 6 tone Selcall) is available and indicated by a ' _ '.
5. Turn the Rotary Channel Selector to select the desired ID.
6. When desired ID is entered press **[SCAN]** to move to Alpha Tag selection.
A cursor flashes in the 1st alpha position. The default alpha tag is blank - displays as No Name. If you do not wish to name the ID then skip to step 9.
7. Turn the Rotary Channel Selector to select the desired alpha character.
8. Use **◀** or **▶** to shift between cursor positions.
9. When finished press **[SCAN]**. A confirmation tone sounds to indicate the ID is programmed. The memory number flashes to enable selection for programming of next memory if desired.
10. Press and hold **[MENU]**, or wait for 10sec, to exit programming mode.

Operation - Special Features

Tone Calling (Making a Selcall Call)

Tone Calling allows you to selectively call other radios.

For convenience, the Selcall ID of the radio you are going to call should be in the Selcall ID memory (see Storing Selcall IDs of other users to the ID Memory p.44). If not then the Selcall ID can be manually entered for this call.





To Call:

1. Select the channel that you and your group agreed to use for Selective Calling.
2. Press **[S]** on the speaker MIC.

A beep tone will sound and the last stored ID or last transmitted ID will be displayed.

3. Press  /  channel selector to select the desired Selcall ID.

If the desired Selcall ID is not stored in the ID memory you can manually enter the ID as follows;

- a) Press **[SCAN]** to begin ID edit. The 5th digit of the ID flashes.
 - b) Use  or  to shift between digits. A 6th digit (for 6 tone Selcall) is available and indicated by a ' _ '.
 - c) Press the  /  channel selector to select the desired ID.
4. Press **[S]** to transmit the Selcall.
CAL will display when transmitting the Selcall.

An acknowledge tone coming from the called radio will be received if you have successfully made contact. The acknowledge tone for the UH9050 is a succession of three low tone beeps.

Operation - Special Features

Receiver Quiet (TSQ) Mode



Puts the receiver in the QUIET mode (also known as the Tone Squelch (TSQ) mode) for the selected channel. When activated, the transceiver prevents any unwanted conversations in the channel from being heard unless the call is specifically directed to you and the Selcall ID required to open the QUIET condition has been received.



NOTE

Under this condition, **PTT** is temporarily disabled. If you wish to use the same Channel for normal communication, simply remove the channel from QUIET mode.

To Activate/Deactivate Tone Squelch (TSQ) on a Channel

1. Press  /  channel selector to select the channel you want to put in or take out of 'QUIET' mode.
2. Press and hold **[TSQ]** for 2 seconds.
Two beeps will sound and the TSQ icon appears on or disappears from the LCD display.

Receiving a Selcall

While in TSQ mode, when UH9050 receives a code matching your Selcall ID, it will perform the following operations:

- a) Automatically responds to the caller by transmitting Acknowledge Tones.
- b) Informs you that a caller is on the Channel by emitting a CALL ALARM (Default Alarm Setting: four successive beeps in a regular interval for 10 seconds. Refer to p.51, 'Alarm Mode' for other alarm settings) and displays the CAL icon.
- c) Flashes the TSQ icon for about 20 seconds allowing you to use the PTT button. If you are not able to respond within the 20 second period, TSQ icon stops flashing and 'QUIET' mode resumes.



NOTE

The UH9050 can decode a Selcall call even though not in 'QUIET' mode.

Operation - Special Features

Scanning Tone Squelched Channels

If you are using two or more Channels in the TSQ mode, you can monitor all of these Channels for selective calls by using the TSQ scanning feature.

To use this feature start the TSQ Scan by pressing and holding **[TSQ]** for 2 seconds during Open Scan, Group Scan or Master Scan.

Unlike Normal Scanning, TSQ scans and checks detected signals for Selcall information. If this information is not found, TSQ Scanning resumes.



When a call is received during TSQ Scanning, UH9050 follows the same response as when receiving a call on a Tone Squelch Channel. It differs only in the following ways:

1. If the call is not answered within 20 seconds, TSQ Scanning resumes.

The CAL icon remains on the LCD display.

To look for the Channel where the CALL is received.

a) Cancel TSQ Scanning by pressing **[SCAN]**.

b) Press  /  channel selector to browse through the TSQ Channels. The CAL indicator marks the Channel where the Call is received.

2. When answered, TSQ Scanning is automatically deactivated. The Channel is removed from the QUIET Operating Mode.

To deactivate TSQ Scanning:

a) Press and hold **[TSQ]** for 2 seconds.
The unit returns to Normal Scanning Mode.

b) Press **[SCAN]**.
The whole scanning operation is cleared.

c) When a Selcall is received, press **PTT**.



NOTE

The chance of receiving and decoding Selcalls effectively during TSQ Scanning can be increased in many different ways. You can either decrease the number of channels to be scanned thus increasing the scanning speed – or – change some of the Selcall parameters (refer to 'Selcall Programming').

Operation - Special Features

Group Calling

The UH9050 has the capability to respond to Group Calling and to transmit Group Calling Codes.

Group Calling allows you to call members of your group simultaneously. However, to do this, you need to follow a certain format (see below) when programming your TX Selcall ID.

Selcall ID Format

To call	Transmitter SELCALL ID
10 radios	[X] [X] [X] [X] [A]
100 radios	[X] [X] [X] [A] [A]
1000 radios	[X] [X] [A] [A] [A]
10000 radios	[X] [A] [A] [A] [A]

where: [X] is a common Selcall ID prefix of your group
- and - [A] is the CCIR Assigned Group Tone Code

Example:

If one group comprises 10 members with Selcall IDs the ID numbers could be as follows:

Group ID #	Individual ID#
[1] [2] [3] [4]	[0]
[1] [2] [3] [4]	[1]
[1] [2] [3] [4]	[2]
[1] [2] [3] [4]	[3]

to -

[1] [2] [3] [4]	[9]
-----------------	-----

all in TSQ mode at CH20

If someone transmits ID 1234A on CH20, all of the above units will open their Tone Squelched Receiver.

Group Calls and ordinary Selcalls can be differentiated in the following manner:

Group Call - Low tone beeps
Ordinary Selcall - High tone beeps

Operation - Special Features

SELCALL Settings

Tone Period



Tone period is the duration of one tone in a Selcall ID sequence. The setting of this parameter depends on the type of application. On long distance communications, for example: where the signal strength of the transmitted information is greatly reduced and affected by noise, it is advisable to use a longer Tone Period. A long Tone Period gives the decoder more time and information to check and evaluate the code.



NOTE

However, be sure that all the radios in your group use the same Tone Period setting. Otherwise you will not be able to selectively call one another.

The UH9050 allows you to select which Tone Period is best for you. The three most commonly used tone settings (40,70 or 100 mSec) are available. With the freedom to change this parameter, you can easily adapt to the existing system in your group without the inconvenience of having the unit serviced by the dealer.

1. Power Off the UH9050.
2. Press and hold **[POWER]** and **[MENU]**. The SELCALL Settings Menu will display (no tone will sound).
3. Press **[MENU]** repeatedly to select the Tone Period setting - which is indicated on the display as Pd.
4. Press **[SCAN]** to edit the setting. The current setting flashes.
5. Press  /  channel selector to select the desired tone period from 40ms, 70ms or 100ms.
6. Press **[SCAN]** to save the setting.
7. Press and hold **[MENU]**, to save and exit programming mode.

Lead-in Delay

Lead-in delay is a Selcall transmission parameter that 'wakes-up' and helps the receiver of the other radio to lock onto the incoming signal. Each time a Selcall ID is transmitted, the Lead-in Delay attaches itself to the beginning of the code sequence and causes the transmitter to be on for a longer period prior to the code transmission. This makes for a stronger communication link between the transmitter and the other receiver.

One major advantage to having the longer Lead-in Delay is when selectively calling another radio via a repeater station. A longer Lead-in Delay helps to stabilise both the communication link from your radio to the repeater station and from the repeater station to the other radio.

Operation - Special Features

Lead-in Delay Programming

1. Power Off the UH9050.
2. Press and hold **[POWER]** and **[MENU]**. The SELCALL Settings Menu will display (no tone will sound).
3. Press **[MENU]** repeatedly to select the Lead-in Delay setting - which is indicated on the display as Ld.
4. Press **[SCAN]** to edit the setting. The current setting flashes.
5. Press **[▲]** / **[▼]** channel selector or turn the Rotary **PWR/VOL** at the base to select the desired Lead-in delay period from 500ms, 1000ms, 2000ms, 3000ms or 4000ms.
6. Press **[SCAN]** to save the setting.
7. Press and hold **[MENU]**, to save and exit programming mode.

Lead-in Tone

The Lead-in Tone, when programmed, 'rides' on the Lead-in Delay. Hence, when transmitting a Selcall ID, a continuous tone will be heard for the duration of the Lead-in Delay. The main purpose of the Lead-in Tone is to increase the probability of contact between your unit and another radio when TSQ Scanning.

1. Power Off the UH9050.
2. Press and hold **[POWER]** and **[MENU]**. The SELCALL Settings Menu will display (no tone will sound).
3. Press **[MENU]** repeatedly to select the Lead-in Tone setting - which is indicated on the display as Lt.
4. Press **[SCAN]** to edit the setting. The current setting flashes.
5. Press **[▲]** / **[▼]** channel selector or turn the Rotary **PWR/VOL** at the base to select the desired Lead-in Tone.



NOTE

- If you want to remove the Lead-in Tone choose the space [_] Bar.

6. Press **[SCAN]** to save the setting.
7. Press and hold **[MENU]**, to save and exit programming mode.

Operation - Special Features

Alarm Mode

When a received code matches to your receiver Selcall ID the UH9050 will respond based on the Call Alarm mode.

Call Alarm - Auto mode (Default)

- a) Transmit an Acknowledge tone to the Caller.
- b) Emit CALL Alarm for 10 seconds only.
- c) Resume Quiet condition automatically after 20 seconds if the call is not answered.
- d) The Unit will start decoding again when the 20 second period elapsed and the call remained unanswered.

Call Alarm - Continue mode

- a) Transmit an Acknowledge Tone to the Caller.
- b) Initially an alarm of four successive beeps is emitted for 20 seconds and then two successive beeps every four seconds continuously unless answered.
- c) The Quiet Condition is never resumed.
- d) The Unit continues to check if incoming codes have your Receiver Selcall ID even though the Quiet Condition is already opened. When detected, it will send an acknowledge Tone to the caller and then resets the Call Alarm.



For both of the above mentioned modes, transmission by using the PTT button is possible when the **TSQ** icon is flashing.

1. Power Off the UH9050.
2. Press and hold **[POWER]** and **[MENU]**. The SELCALL Settings Menu will display (no tone will sound).
3. Press **[MENU]** repeatedly to select the Alarm mode setting - which is indicated on the display as AL.
4. Press **[SCAN]** to edit the setting. The current setting flashes.
5. Press **[▲]** / **[▼]** channel selector or turn the Rotary **PWR/VOL** at the base to select the desired Alarm mode from AUTO or CONT.
6. Press **[SCAN]** to save the setting.
7. Press and hold **[MENU]**, to save and exit programming mode.

Group Call Mode

The Group Tone period can be adjusted to increase the ability to identify group calls. Group 01 mode sets the tone period to 1 tone period (default). Group 02 mode sets the first group tone period to 3 tone periods.

1. Power Off the UH9050.
2. Press and hold **[POWER]** and **[MENU]**. The SELCALL Settings Menu will display (no tone will sound).
3. Press **[MENU]** repeatedly to select the Group Call mode setting - which is indicated on the display as GROUP.
4. Press **[SCAN]** to edit the setting. The current setting flashes.
5. Press **[▲]** / **[▼]** channel selector or turn the Rotary **PWR/VOL** at the base to select the desired Group Call mode from 01 or 02.
6. Press **[SCAN]** to save the setting.
7. Press and hold **[MENU]**, to save and exit programming mode.

SELCALL Tone Frequency List

Tone No.	Tone Frequency (Hz)	Tone No.	Tone Frequency (Hz)
0	1981	8	1747
1	1124	9	1860
2	1197	A (Group)	2400
3	1275	B	930
4	1358	C	2247
5	1446	D	991
6	1540	E (Repeat)	2110
7	1640	F	1055

CTCSS Codes Table

Code No.	Frequency (Hz)	Code No.	Frequency (Hz)
"oF"	OFF	20	131.8
1	67.0	21	136.5
2	71.9	22	141.3
3	74.4	23	146.2
4	77.0	24	151.4
5	79.7	25	156.7
6	82.5	26	162.2
7	85.4	27	167.9
8	88.5	28	173.8
9	91.5	29	179.9
10	94.8	30	186.2
11	97.4	31	192.8
12	100.0	32	203.5
13	103.5	33	210.7
14	107.2	34	218.1
15	110.9	35	225.7
16	114.8	36	233.6
17	118.8	37	241.8
18	123.0	38	250.3
19	127.3		

DCS Codes Table

Code No.	DCS Code (Octal)	Code No.	DCS Code (Octal)	Code No.	DCS Code (Octal)
1	023	36	223	71	445
2	025	37	225	72	446
3	026	38	226	73	452
4	031	39	243	74	454
5	032	40	244	75	455
6	036	41	245	76	462
7	043	42	246	77	464
8	047	43	251	78	465
9	051	44	252	79	466
10	053	45	255	80	503
11	054	46	261	81	506
12	065	47	263	82	516
13	071	48	265	83	523
14	072	49	266	84	526
15	073	50	271	85	532
16	074	51	274	86	546
17	114	52	306	87	565
18	115	53	311	88	606
19	116	54	315	89	612
20	122	55	325	90	624
21	125	56	331	91	627
22	131	57	332	92	631
23	132	58	343	93	632
24	134	59	346	94	654
25	143	60	351	95	662
26	145	61	356	96	664
27	152	62	364	97	703
28	155	63	365	98	712
29	156	64	371	99	723
30	162	65	411	100	731
31	165	66	412	101	732
32	172	67	413	102	734
33	174	68	423	103	743
34	205	69	431	104	754
35	212	70	432		

Channel Bank List - Police (POL)

Code No.	Frequency (MHz)	Code No.	Frequency (MHz)	Code No.	Frequency (MHz)
1	419.95000	26	468.27500	51	468.85000
2	465.50000	27	468.30000	52	468.87500
3	465.97500	28	468.32500	53	468.90000
4	466.25000	29	468.35000	54	468.92500
5	466.77500	30	468.37500	55	468.95000
6	466.85000	31	468.40000	56	468.97500
7	467.12500	32	468.42500	57	469.00000
8	467.65000	33	468.45000	58	469.02500
9	467.85000	34	468.47500	59	469.05000
10	467.87500	35	468.50000	60	469.07500
11	467.90000	36	468.52500	61	469.10000
12	467.92500	37	468.55000	62	469.12500
13	467.95000	38	468.57500	63	469.15000
14	467.97500	39	468.60000	64	469.17500
15	468.00000	40	468.61250	65	469.20000
16	468.02500	41	468.62500	66	469.22500
17	468.05000	42	468.63750	67	469.25000
18	468.07500	43	468.65000	68	469.27500
19	468.10000	44	468.67500	69	469.30000
20	468.12500	45	468.70000	70	469.32500
21	468.15000	46	468.72500	71	469.35000
22	468.17500	47	468.75000	72	469.37500
23	468.20000	48	468.77500	73	469.40000
24	468.22500	49	468.80000	74	469.42500
25	468.25000	50	468.82500	75	469.70000

Channel Bank List - Fire

Code No.	Frequency (MHz)	Code No.	Frequency (MHz)	Code No.	Frequency (MHz)
1	410.60000	36	413.27500	71	462.86250
2	410.80000	37	413.30000	72	463.05000
3	411.01250	38	413.32500	73	463.12500
4	411.03750	39	413.35000	74	463.27500
5	411.06250	40	413.36250	75	463.32500
6	411.08750	41	413.37500	76	463.65000
7	412.32500	42	413.38750	77	463.70000
8	412.45000	43	413.40000	78	463.87500
9	412.47500	44	413.42500	79	465.02500
10	412.55000	45	414.52500	80	465.07500
11	412.57500	46	414.6625	81	465.17500
12	412.60000	47	415.11250	82	465.32500
13	412.65000	48	415.26250	83	465.65000
14	412.70000	49	415.41250	84	465.67500
15	412.72500	50	416.17500	85	466.55000
16	412.75000	51	416.28750	86	466.60000
17	412.80000	52	416.41250	87	466.85000
18	412.85000	53	416.51250	88	466.87500
19	412.87500	54	416.53750	89	466.92500
20	412.95000	55	416.67500	90	466.95000
21	413.02500	56	416.78750	91	466.97500
22	413.05000	57	416.91250	92	467.25000
23	413.07500	58	417.03750	93	467.42500
24	413.10000	59	417.17500	94	467.47500
25	413.11250	60	417.28750	95	467.50000
26	413.12500	61	417.41250	96	467.67500
27	413.13750	62	417.53750	97	467.77500
28	413.15000	63	419.15000	98	468.62500
29	413.16250	64	419.40000	99	469.52500
30	413.17500	65	419.96250	100	469.57500
31	413.18750	66	462.02500	101	469.60000
32	413.20000	67	462.20000	102	469.90000
33	413.21250	68	462.70000	103	471.85000
34	413.25000	69	462.78750	104	507.57500
35	413.26250	70	462.82500		

UHF-CB Channel Guidelines

Always listen on a channel (or observe the receive signal level meter) to ensure it is not already being used before transmitting.

Channels 5 and 35 are used for emergency channels.

CTCSS, DCS, TSQ and SELCALL will not operate on these channels.

Please follow these guidelines for channel use in Australia:

- Channels 05 and 35 are Emergency Channels.
- Channel 11 is a Calling Channel.
- Channels 22 and 23 are for telemetry and telecommand applications, channels 61, 62 and 63 are for future use and TX is inhibited on these channels.



NOTE

General communication is accepted on all other channels with these guidelines:

- Channel 40 - road channel (Australia).
- Channels 01-08 (and 31-38), and Channels 41-48 (and 71-78) are repeater channels.

Important information - 80 Channel UHF-CB channel expansion

To provide all users additional channel capacity within the UHF-CB Band. The ACMA will change the majority of the current wideband 40 channel use to narrowband channel use. This allows for additional channels to be added, up to 80 Channels.

This simply means that the new narrowband radio you have purchased will have more channels than older radios. Please refer to the guidelines above and the channel chart for further channel information.

A list of currently authorised channels can also be obtained from the ACMA website in Australia and the MBIE website in New Zealand.

Interference / Poor Audio



NOTE

When a new narrowband radio receives a signal from an older wideband radio the speech may sound loud - however the radio's built-in AVS (Automatic Volume Stabilizer) circuitry will detect and manage incoming audio to comparable levels.

Narrowband radios operating on CH41 - CH80 may encounter interference from a nearby wideband radios transmitting on high power on an adjacent channel (frequency).

When an older wideband radio receives a signal from a new narrowband radio the speech may sound quiet - the wideband radio user simply adjusts their radio volume for best performance.

The above situations are not a fault of the radio but a symptom of mixed wideband and narrowband radios in current use. It is expected that as older wideband radios are phased out this issue will be eliminated.

UHF-CB Channels and Frequencies

CH No.	Simplex Mode Transmit / Receive Frequency (MHz)	Duplex Mode Transmit Frequency (MHz)	CH No.	Simplex Mode Transmit / Receive Frequency (MHz)
1	476.425	477.175 (CH31)	21	476.925
2	476.450	477.200 (CH32)	22	476.950 (RX only)
3	476.475	477.225 (CH33)	23	476.975 (RX only)
4	476.500	477.250 (CH34)	24	477.000
5	476.525	477.275 (CH35)	25	477.025
6	476.550	477.300 (CH36)	26	477.050
7	476.575	477.325 (CH37)	27	477.075
8	476.600	477.350 (CH38)	28	477.100
9	476.625		29	477.125
10	476.650		30	477.150
11	476.675		31	477.175
12	476.700		32	477.200
13	476.725		33	477.225
14	476.750		34	477.250
15	476.775		35	477.275
16	476.800		36	477.300
17	476.825		37	477.325
18	476.850		38	477.350
19	476.875		39	477.375
20	476.900		40	477.400

UHF-CB Channels and Frequencies

CH No.	Simplex Mode Transmit / Receive Frequency (MHz)	Duplex Mode Transmit Frequency (MHz)	CH No.	Simplex Mode Transmit / Receive Frequency (MHz)
41	476.4375	477.1875 (CH 71)	61	future use 476.9375 (RX only)
42	476.4625	477.2125 (CH 72)	62	future use 476.9625 (RX only)
43	476.4875	477.2375 (CH 73)	63	future use 476.9875 (RX only)
44	476.5125	477.2625 (CH 74)	64	477.0125
45	476.5375	477.2875 (CH 75)	65	477.0375
46	476.5625	477.3125 (CH 76)	66	477.0625
47	476.5875	477.3375 (CH 77)	67	477.0875
48	476.6125	477.3625 (CH 78)	68	477.1125
49	476.6375		69	477.1375
50	476.6625		70	477.1625
51	476.6875		71	477.1875
52	476.7125		72	477.2125
53	476.7375		73	477.2375
54	476.7625		74	477.2625
55	476.7875		75	477.2875
56	476.8125		76	477.3125
57	476.8375		77	477.3375
58	476.8625		78	477.3625
59	476.8875		79	477.3875
60	476.9125		80	477.4125

Warranty

UNIDEN UH9050 UHF CB Transceiver

IMPORTANT: Satisfactory evidence of the original purchase is required for warranty service

Please refer to our Uniden website for any details or warranty durations offered in addition to those contained below.

Warrantor: The warrantor is Uniden Australia Pty Limited ABN 58 001 865 498 (“Uniden Aust”).

Terms of Warranty: Uniden Aust warrants to the original retail purchaser only that the UH9050 UHF CB Transceiver (“the Product”), will be free from defects in materials and craftsmanship for the duration of the warranty period, subject to the limitations and exclusions set out below.

Warranty period: This warranty to the original retail purchaser is only valid in the original country of purchase for a Product first purchased either in Australia or New Zealand.

Product	5 Years
Battery Pack & Accessories	1 Year

If a warranty claim is made, this warranty will not apply if the Product is found by Uniden to be:

- (A) Damaged or not maintained in a reasonable manner or as recommended in the relevant Uniden Owner’s Manual;
- (B) Modified, altered or used as part of any conversion kits, subassemblies or any configurations not sold by Uniden Aust;
- (C) Improperly installed contrary to instructions contained in the relevant Owner’s Manual
- (D) Repaired by someone other than an authorized Uniden Repair Agent in relation to a defect or malfunction covered by this warranty; or
- (E) Used in conjunction with any equipment, parts or a system not manufactured by Uniden.

Parts Covered: This warranty covers the Product and included accessories.

User-generated Data: This warranty does not cover any claimed loss of or damage to user-generated data (including but without limitation phone numbers, addresses and images) that may be stored on your Product.

Warranty

Statement of Remedy: If the Product is found not to conform to this warranty as stated above, the Warrantor, at its discretion, will either repair the defect or replace the Product without any charge for parts or service. This warranty does not include any reimbursement or payment of any consequential damages claimed to arise from a Product's failure to comply with the warranty.

Our goods come with guarantees that cannot be excluded under the Australian Consumer Law. You are entitled to a replacement or refund for a major failure and for compensation for any other reasonably foreseeable loss or damage. You are also entitled to have the goods repaired or replaced if the goods fail to be of acceptable quality and the failure does not amount to a major failure.

This warranty is in addition to and sits alongside your rights under either the COMPETITION AND CONSUMER ACT 2010 (Australia) or the CONSUMER GUARANTEES ACT (New Zealand) as the case may be, none of which can be excluded.

Procedure for obtaining warranty service: Depending on the country in which the Product was first purchased, if you believe that your Product does not conform with this warranty, you should deliver the Product, together with satisfactory evidence of your original purchase (such as a legible copy of the sales docket) to Uniden at the address shown below. You should contact Uniden regarding any compensation that may be payable for your expenses incurred in making a warranty claim. Prior to delivery, we recommend that you make a backup copy of any phone numbers, images or other data stored on your Product, in case it is lost or damaged during warranty service.

UNIDEN AUSTRALIA PTY LTD

Phone: 1300 366 895

Email: custservice@uniden.com.au

THANK YOU FOR BUYING A UNIDEN PRODUCT.

Uniden[®]

© 2017 Uniden Australia Pty Limited. Printed in Vietnam.
U01UT982ZZZ(0)