

Uniden[®]

UM425 VHF DSC
Marine Radio

OWNER'S MANUAL

NOTE: There is no official VHF DSC shore infrastructure in Australia. Vessels fitting VHF DSC equipment should realise that this equipment can only be used for vessel - to - vessel alerting in the Australian region. There is no official shore-based infrastructure but there are a number of volunteer marine rescue (VMR) stations that have installed VHF DSC and a check with your local VMR should be made.

Making a DSC DISTRESS Call

Lift the red cover. Press and hold the **DISTRESS** button for three seconds. The UM425 transmits your boat's location every few minutes until you receive a response.

NOTE: If the radio displays *ENTER USER MMSI*, cancel the automatic distress call and make a normal voice distress call.

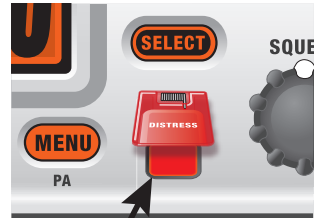

Lift the red cover and press the **DISTRESS** button.

Making a voice distress call

Speak slowly -- clearly -- calmly.

For future reference, write your boat's name & call sign here:

1. Make sure your radio is on.
2. On the microphone, press the **16/9-TRI** button to switch to Channel 16 (156.8 MHz). (If the corner of the display does not show 16, press the **16/9-TRI** button again until it does.)
3. Press the **PUSH TO TALK** button on the microphone and say: **"MAYDAY --MAYDAY-- MAYDAY."**
4. Say **"THIS IS {name or call sign of your boat}."**
5. Say **"MAYDAY {name or call sign of your boat}."**
6. Tell where you are: (what navigational aids or landmarks are near, or read the latitude and longitude from your GPS).
7. State the nature of your distress, e.g. are you sinking, medical emergency, man overboard, on fire, adrift, etc.
8. Give number of persons aboard and conditions of any injured persons.
9. Estimate present seaworthiness of your ship, e.g. how immediate is the danger due to flooding or fire or proximity to shore.
10. Briefly describe your ship (length, type, color, hull).
11. Say: **"I WILL BE LISTENING ON CHANNEL 16."**
12. End message by saying **"THIS IS {name or call sign of your boat}, OVER."**
13. Release the **PUSH TO TALK** button and listen.
If you do not get an answer after 30 seconds, repeat your call, beginning at step 3, above.

Table of Contents

Making a DSC DISTRESS Call	2
<i>Making a voice distress call</i>	2
Table of Contents	4 (this page)
Introduction	6
<i>Features</i>	6
<i>Manual overview</i>	6
Conventions.....	6
Terms used in this manual.....	7
Getting Started	8
<i>What's included</i>	8
<i>Parts of the radio</i>	9
<i>Turning on the radio</i>	12
<i>Setting the UIC channel mode (USA/CAN/INT)</i>	12
How It Works	12
<i>Normal mode operation</i>	13
Using the radio in normal mode.....	14
Normal mode with Triple and Dual Watch.....	15
<i>Scan mode</i>	16
Using the radio in scan mode.....	16
Scan mode with Triple and Dual Watch.....	17
Using Your Radio	18
<i>Making a voice MAYDAY call</i>	19
<i>Setting the volume</i>	19
<i>Setting the squelch level</i>	19
<i>Changing the channel</i>	20
<i>Making a transmission</i>	20
Boosting the transmission power.....	20
Choosing Triple Watch or Dual Watch.....	21
<i>Changing display and sound options</i>	22
Contrast.....	22
Lamp adjust.....	22
Turning the key beep on and off.....	22
<i>Setting the GPS position manually</i>	22
Using Digital Selective Calling (DSC) Features	24
<i>What is DSC?</i>	24
<i>Advanced DSC features</i>	24
<i>Getting an MMSI number</i>	25
<i>Entering MMSI numbers</i>	25
Individual or user MMSI number.....	25
Group MMSI number.....	26
<i>Using the directory</i>	27
<i>Making DSC calls</i>	29
Calling a single station (Individual Call).....	30
Calling a particular group of stations (Group Call).....	31
Calling all stations (All-Ships Call).....	31
Making an automatic distress call.....	32
Canceling an automatic distress call.....	32
<i>Receiving a DSC call</i>	33
<i>Receive log</i>	33
Returning a call.....	34
<i>Making a Test Call (Test)</i>	35
Receiving a test call.....	36

Enabling automatic test call reply	36
Requesting another station's position (POS Request)	36
Receiving a position request (Position Reply)	37
Enabling automatic position reply	37
Sending your own position (Position Send)	38
Putting the radio into standby	38
Disabling automatic channel switching	39
Renaming Channels	40
Installing the Hardware	41
Mounting the radio	41
Connecting the radio	43
Connecting accessories	45
Connecting to a GPS receiver	45
Configuring the GPS	47
Connecting to a chartplotter	48
Connecting to an external speaker	48
Connecting to an external PA speaker	49
Using the PA feature	50
Maintenance and Troubleshooting	51
Common questions	51
Engine Noise Suppression	53
Specifications	54
Channel and frequencies	57
NMEA Operation	63
NMEA Input	63
NMEA Output	63
Regulations and Safety Warnings	64
Basic radio guidelines	64
DSC: Frequently Asked Questions	64
Antenna Selection and Installation	65
Two Year Limited Warranty	66
Mounting Bracket Template	67

List of Tables

Table 1 - Terms used in this manual	7
Table 2 - Rear panel connector functions	9
Table 3 - Front panel button functions	10
Table 4 - Microphone button functions	11
Table 5 - Normal mode status messages	14
Table 6 - Character and text entry order	28
Table 7 - Receive log	34
Table 8 - Common GPS receivers and connections	46
Table 9 - Radio specifications	54
Table 10 - International Channel Frequencies and Channel Tag	57
Table 11 - USA Channel Frequencies and Channel Tag	59
Table 12 - Canadian Channel Frequencies and Channel Tag	61
Table 13 - NMEA Input Parameters	63

Introduction

Features

- **Watertight Radio Housing:**
Meets the worldwide JIS6 water resistant specification means it is able to withstand powerful water jets without damage.
- **Rugged Waterproof Speaker Microphone:**
With Channel Select, One-Touch 16/9 and Triple Watch Select Keys.
Meets the worldwide JIS7 waterproof specifications; submersible at 1.0 metre depth for 30 minutes.
- **Large, dot matrix display**
- **Advanced DSC Class D functions, including Test Calling**
- **Built-in PA output**
- **Channel select buttons on the microphone**
- **Memory scan mode**
Lets you save channels to memory and monitor them in quick succession.
- **Transmitter Power Level Select**
Lets you boost the transmitter power from 1 watt to 25 watts for added transmission distance.
- **Battery level display and tone**
Sounds an alert tone if the battery voltage goes too high or too low.
- **Triple Watch Operation**
Checks the emergency channel 16 and channel 9 in the background.
- **All marine VHF channels for the International, U.S. and Canadian waters**

Manual overview

Conventions

This manual uses several different type styles to help you distinguish between different parts of the radio:

- **BOLD SMALL CAPITALS** indicates an actual button or knob on the radio or microphone.
- **Upper and Lower case bold** indicates a connector or label on the radio.
- *Italics* indicate text on the display, such as menu options, prompts, and confirmation messages.

Table 1 - Terms used in the manual

DSC	Digital Selective Calling. A VHF radio standard for communicating among boats and sending automated distress calls.
GPS	Global Positioning System
NMEA	National Marine Electronics Association. The organization that governs standards for electronic equipment used on boats. NMEA 0183 is the standard for serial data communication used by GPS receivers.
MMSI	Maritime Mobile Service Identity number. A unique, nine-digit number that identifies you and your boat when making DSC calls. It is also used by the Coast Guard if you send an automated distress call.
Station	Any DSC radio, whether it's operated on a boat, at a marina, or by a shore station.

Getting Started

What's included

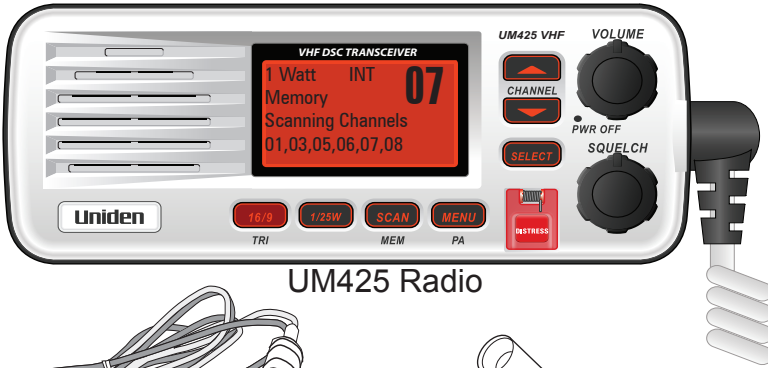

UM425 Radio

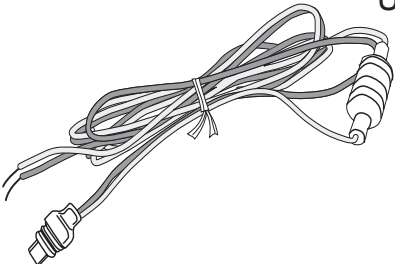

DC Power Cable

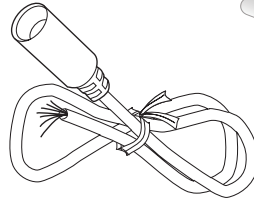

Accessory Cable

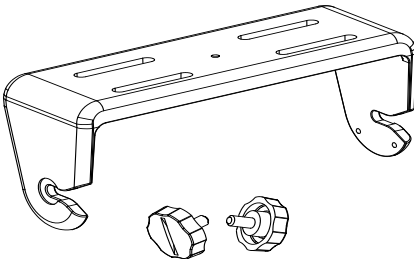

Mounting Bracket and knobs

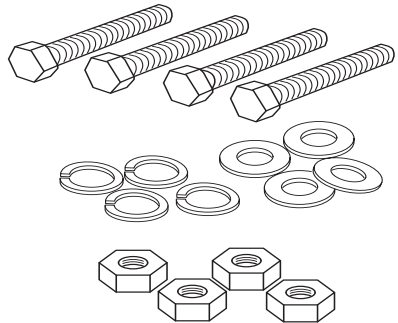

Mounting Hardware

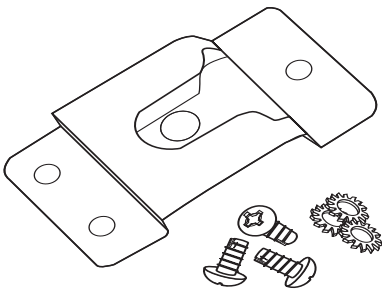

Microphone Hanger and Mounting Hardware

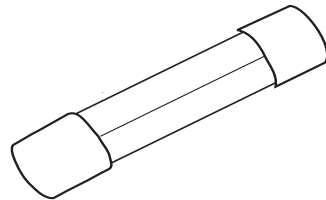

Spare Fuse 250V 6A

Parts of the radio

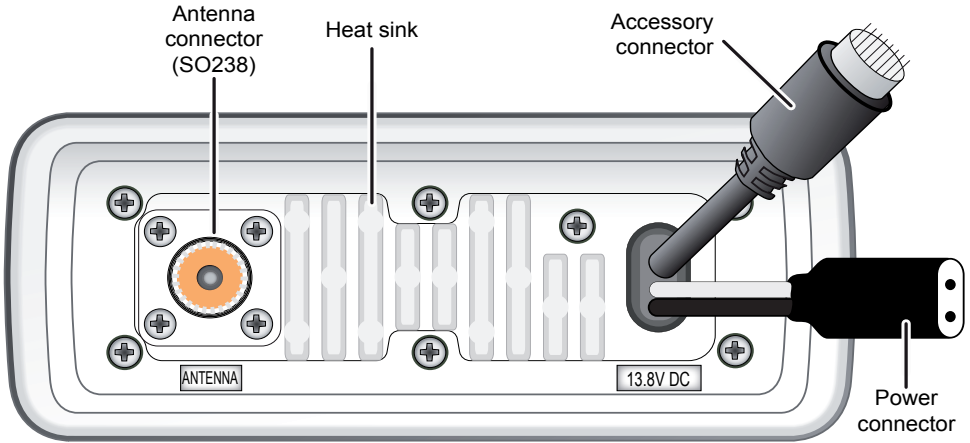

Table 2 - Rear panel connector functions

Connector	Connects to	For details, see
Antenna connector	External VHF antenna with a male PL259 (SO238) connector and 50 Ω impedance. Minimum 1.2m, 3dB rated antenna for sailboats, 2.4m, 6 dB rated for power boats.	Connecting the radio, page 44.
Power connector	Nominal 13.8 VDC power supply with negative ground (10.8 VDC to 15.6 VDC) (Red wire +, black wire -).	Connecting the radio, page 43.
Accessory connector	GPS receiver, GPS chartplotter, external speaker, external PA speaker.	Connecting accessories, page 45.

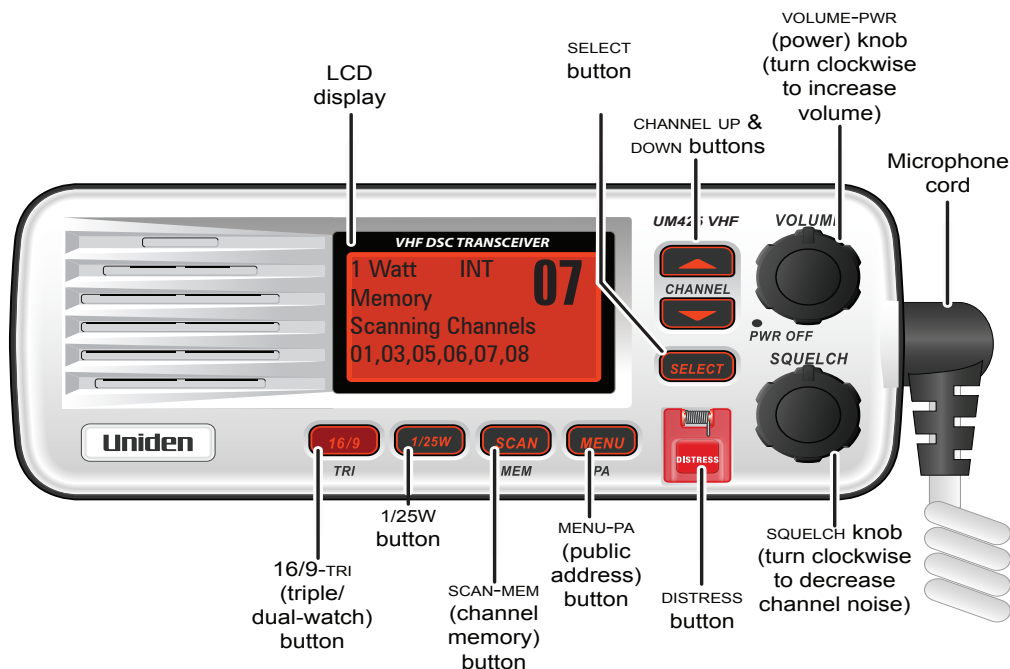

Table 3 - Front panel button functions

Button	Press to...	Press and hold to...
SELECT	Choose an option on a menu.	
CHANNEL UP	Move up one channel at a time.	Move quickly up the channels.
CHANNEL DOWN	Move down one channel at a time.	Move quickly down the channels.
16/9-TRI	1 st press: Go to Channel 16. 2 nd press: Go to Channel 9. 3 rd press: Go back to the original channel.	Go into Triple Watch or Dual Watch mode (see page 15).
DISTRESS	Select the nature of your distress for a distress call.	Transmit a distress call.

Button	Press to...	Press and hold to...
1/25W	Change the transmit power (see page 20).	
MENU-PA	Display the radio menu.	Use the public address (PA) function.
SCAN-MEM	Start scanning the channels saved in memory.	Save a channel into memory or remove a channel from memory.

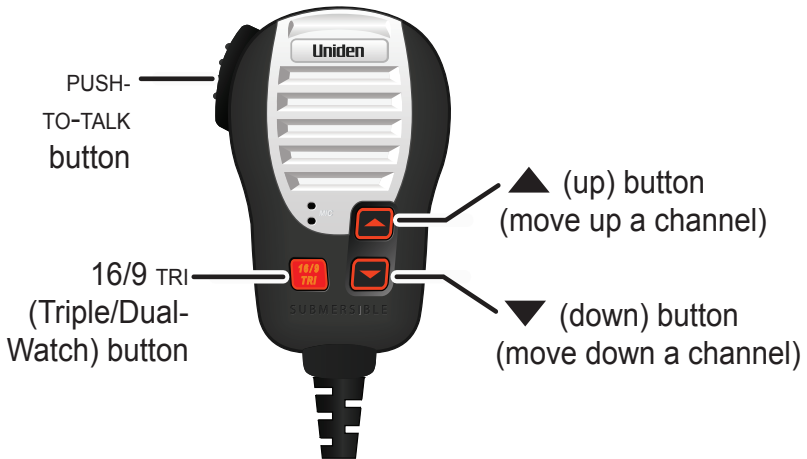

Table 4 - Microphone button functions

Button	Press to...	Press and hold to...
▲	Move up one channel at a time.	Move quickly up the channels.
▼	Move down one channel at a time.	Move quickly down the channels.
16/9-TRI	1 st press: Go to Channel 16. 2 nd press: Go to Channel 9. 3 rd press: Go back to the original channel.	Go into Triple Watch or Dual Watch mode (see page 15).
PUSH TO TALK	Cancel scanning and stay on a channel.	Talk on a channel.

Turning on the radio

Turn the **VOLUME-PWR** knob clockwise to turn on the radio. As it powers on, the radio displays the user MMSI number; if there is no MMSI set, the radio displays *MMSI not entered*.

When it powers on, the radio selects the last channel used.

Setting the UIC channel mode (USA/CAN/INT)

NOTE: This menu selection is hidden by default. To access this feature; Turn on the radio while holding down **SCAN** and ▲ buttons. The feature will be hidden again from the menu when power is turned off. The radio comes preset to use the UIC channels assigned for International waters. If you are operating in an area that uses Canadian or United States UIC channels, you will need to change the channel mode.



1. Press the **MENU-PA** button to display the menu, and choose the *Setup* sub-menu.
2. Select *USA/CAN/INT*. The screen displays the UIC channel setup.
3. Highlight the channel mode you want to use: US (*USA mode*), Canadian (*Canada mode*), or international (*Intl mode*).
4. Press the **SELECT** button. The radio activates the new channel mode and exits the menu.

How It Works

The UM425 has two basic modes of operation:

Operation mode	What it does:	Use it when:	To turn it on/off:
Normal mode	Monitors a single marine radio channel and lets you talk on that channel.	You want to talk to another station on a specific channel.	(default mode)
Scan mode	Monitors all the channels you save into memory.	You have a small group of channels you use most often and want to check them for traffic.	Press the SCAN-MEM button.

In addition to the two main operation modes, the UM425 also provides two different “watch” modes which you can activate during any of the two basic modes. In the watch modes, the radio briefly checks for activity on a specific channel, then returns to its previous mode.

Watch mode	What it does:	Use it when:	To turn it on/off:
Triple Watch	Checks for activity on channels 16 and 9 every two seconds.	You want to monitor a channel yet maintain a watch on channels 16 and 9.	Press and hold the 16/9-TRI button for two seconds.
Dual Watch	Checks for activity on channel 16 every two seconds.	You want to monitor a channel yet maintain a watch on channel 16.	Change Triple Watch to Dual Watch in the setup menu, then press and hold the 16/9-TRI button for two seconds.

NOTE: You are required to monitor channel 16 whenever your boat is underway. You should have either Triple Watch or Dual Watch on at all times.

Normal mode operation

Normal mode monitors whatever channel you select, and you can transmit on that channel also.

While using normal mode, the display lets you see the following information (not all indicators will display at the same time):

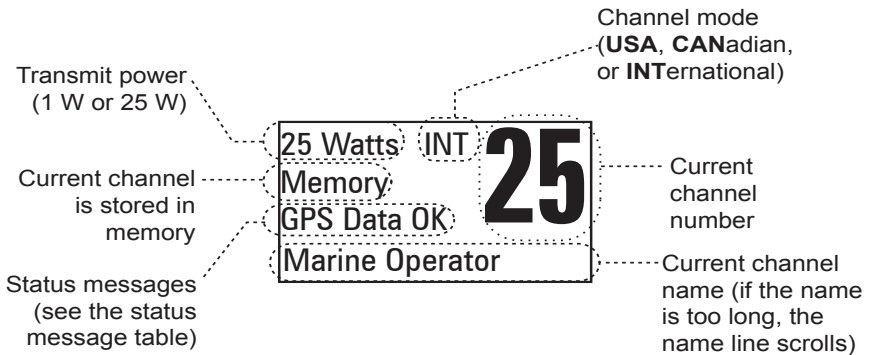

Table 5 - Normal mode status messages

Message	Meaning
GPS Data OK	The radio is receiving valid GPS data.
Check GPS	The radio is not receiving valid GPS data: check the GPS status screen and the GPS connection.
Input Position	The radio has been unable to receive valid GPS data for at least four hours; it can no longer track your position. You need to manually input your position (see <i>Setting the GPS position manually</i> on page 22).
Battery Low	The battery voltage output is too low (below 10.5 VDC).
Battery High	The battery voltage output is too high (above 16.0 VDC).
Triple Watch	Triple Watch is turned on.
Dual Watch	Dual Watch is turned on.

Using the radio in normal mode

- To transmit, press and hold the **PUSH TO TALK** button on the microphone. Release the button when you are finished talking.
- For the best sound quality, hold the microphone about two inches from your mouth while you're talking.
- Press the **CHANNEL UP** button on the radio or the ▲ button on the microphone to move up one channel at a time. Press and hold either button to scroll quickly up the channels.
- Press the **CHANNEL DOWN** button on the radio or the ▼ button on the microphone to move down one channel at a time. Press and hold either button to scroll quickly down the channels.
- To change the transmit power, press the **1/25W** button. The transmit power switches between 1 watt and 25 watts each time you press the **1/25W** button.

Normal mode with Triple and Dual Watch

If you activate Triple Watch while operating in normal mode, the radio checks channels 16 and 9 every two seconds; with Dual Watch turned on, the radio only checks channel 16. The radio will not check channels 16 or 9 while you are actively transmitting; it waits until your transmission is finished and then checks the channels.

Press and hold the **16/9-TRI** button (on the radio or the microphone) for two seconds to turn Triple/Dual Watch on or off. (To change between Triple or Dual Watch, see page 21.)

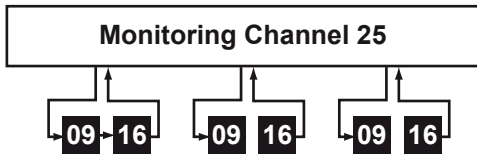

Every 2 seconds, the radio checks channels 9 & 16.

with Triple Watch on

Scan mode

You can save channels into memory and then use scan mode to monitor those channels. When the radio detects a signal on a channel, it pauses on that channel as long as the signal is received; when the transmission stops, the radio will continue scanning.

When it detects a signal, the radio stays on the channel until you press the **CHANNEL UP** button or the signal stops.

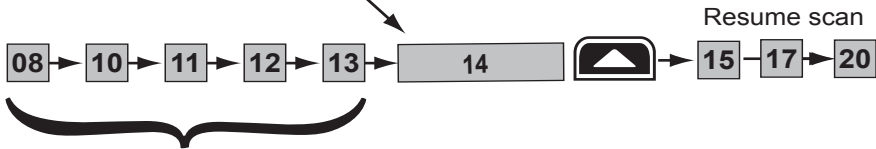

The radio scans about 5 channels in 1 second.

In scan mode, you can get the following information from the display (some indicators will not always be displayed):

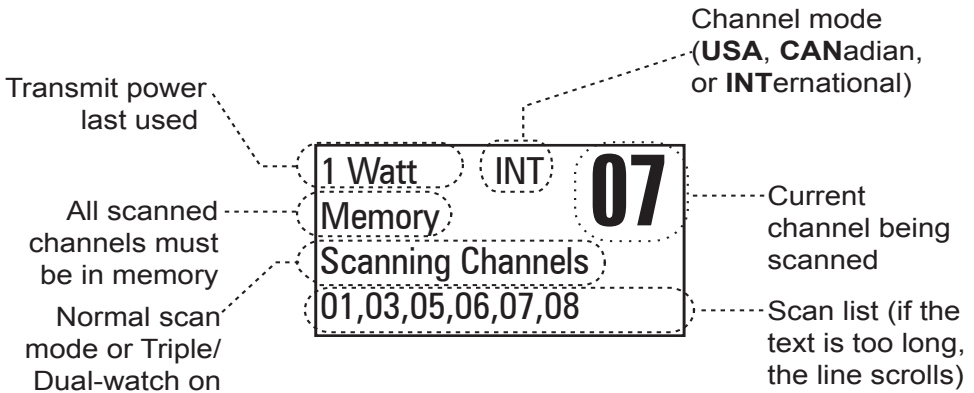

Using the radio in scan mode

- You cannot transmit while in scan mode.
- You must have two or more channels in memory to start a scan.
- To save a channel into memory, select the channel, then press and hold the **SCAN-MEM** button for two seconds. *Memory* will show on the display.

- To remove a channel from memory, set the radio to that channel, then press and hold the **SCAN-MEM** button for two seconds. *Memory* will no longer show on the display.
- To activate scan mode, press the **SCAN-MEM** button. Press the **SCAN-MEM** button again to return to the previous mode.
- When the radio automatically stops on a channel, press the **CHANNEL UP** button to leave that channel and resume scanning.
- To end the scan, press the microphone **PUSH TO TALK** button or the **SCAN-MEM** button. The radio remains on the last scanned channel.

Scan mode with Triple and Dual Watch

If you activate Triple Watch while operating in scan mode, the radio checks channels 16 and 9 every two seconds, then goes on to scan the next channel; with Dual Watch turned on, the radio only checks channel 16:

Press and hold the **16/9-TRI** button (on the radio or the microphone) for two seconds to turn Triple/Dual Watch on or off. (To change between Triple or Dual Watch, see page 21.)

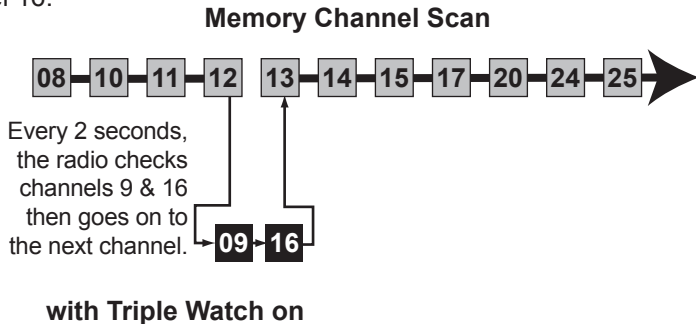

Using Your Radio

To display the radio menu, press the **MENU-PA** button. The menu has the following options:

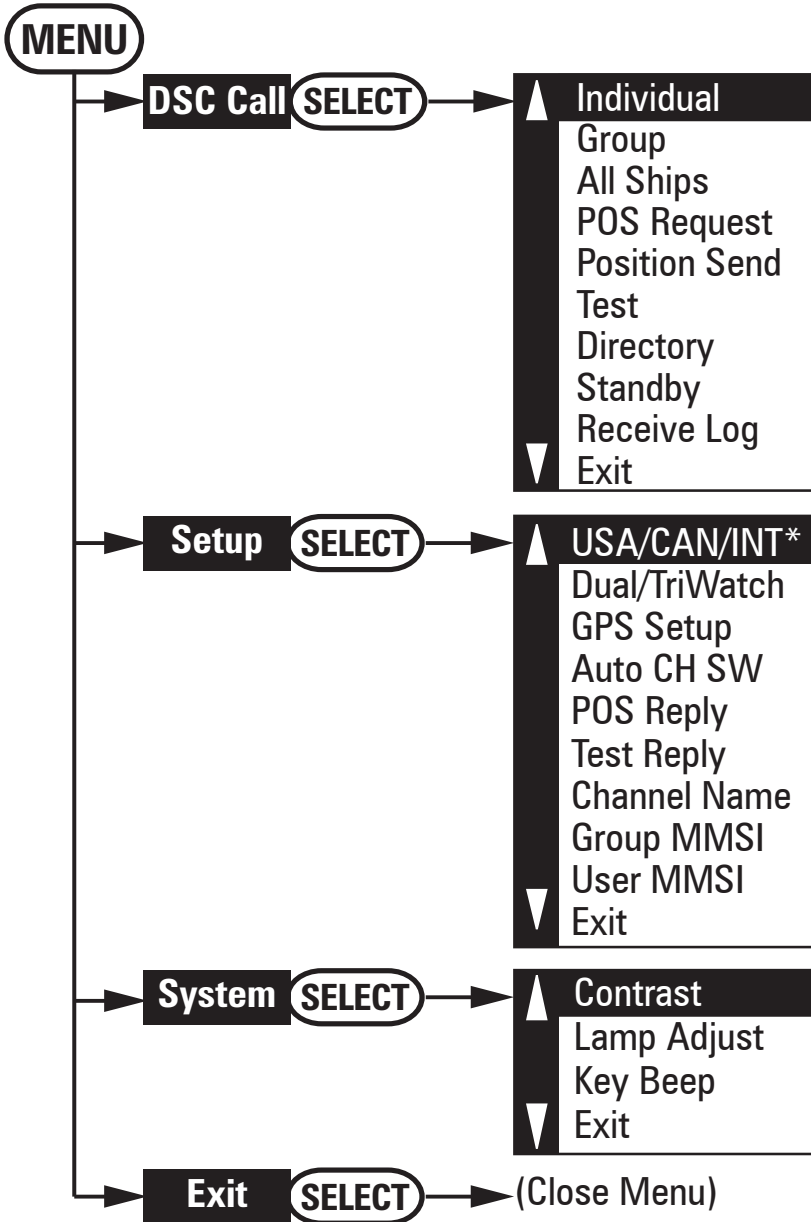

*USA/CAN/INT is hidden by default. See page 12 for instructions to access this selection.

- The currently selected item is highlighted in reversed out text.
- Press the **CHANNEL UP** button on the radio or the ▲ button on the microphone to move up a line in the menu; if you are at the top line in the menu, the cursor jumps to the bottom of the menu.
- Press the **SELECT** button to choose the selected item.
- Press the **CHANNEL DOWN** button on the radio or the ▼ button on the microphone to move down a line in the menu; if you are at the bottom line of the menu, the cursor jumps to the top of the menu.
- Press the **MENU-PA** button to go back to the previous menu screen.
- From any menu screen, choose *Exit* or press the **16/9-TRI** button to close the menu screen.

Making a voice MAYDAY call

(see inside front cover)

Setting the volume

Turn the volume knob clockwise to increase the speaker volume; turn it counter-clockwise to decrease the volume.

Setting the squelch level

The squelch feature reduces the level of static on the speaker by filtering out the background channel noise. At the lowest squelch level, the speaker plays all radio signals, including any noise on the channel. Setting the squelch level higher filters out channel noise and lets only actual radio transmissions through.

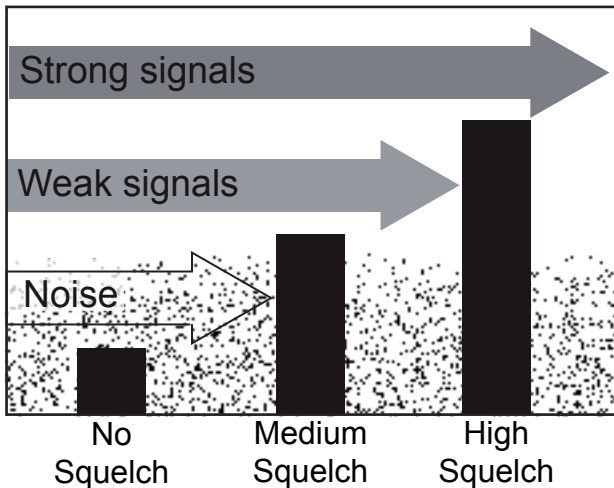

While listening to a channel, adjust the **SQUELCH** knob until the noise is filtered out and you can only hear the transmission. If you switch to a channel with a lot of noise or with a weak transmission, you may need to adjust the squelch level again.

NOTE: Setting the squelch level too high may prevent you from hearing weaker transmissions. If you are having difficulty hearing a transmission, try setting the squelch level lower.

Changing the channel

Press the **CHANNEL UP** or **CHANNEL DOWN** buttons briefly to scroll through the channels one channel at a time. Press and hold the channel up or down button to quickly scroll through the channels.

Making a transmission

To make a transmission, press and hold the microphone **PUSH TO TALK** button. Release the **PUSH TO TALK** button when you're finished talking to let the other party respond.

- To prevent stuck microphone problems or situations where the **PUSH TO TALK** button is pushed accidentally, the radio limits your talk time to 5 minutes in a single transmission. If you talk for over 5 minutes continuously, the display shows *RELEASE MIC BUTTON*.
- For the best sound quality, hold the microphone about two inches away from your mouth.
- You cannot transmit while the radio is in scan mode.
- See the channel list on page 57 for a list of receive-only channels.

Boosting the transmission power

In most situations, the 1 Watt transmission power is all you need. If you find yourself far away from other stations and have trouble getting a response, you may need to boost the transmission power from 1 Watt to 25 Watts:

1. Select the channel you want to transmit on.
2. Push the **1/25W** button. The display shows *25 Watts* in the upper left hand corner.
3. The transmit power remains at 25 Watts until you change the setting back. Push the **1/25W** button. The display shows *1 Watt*.

NOTE: Don't forget to change the transmission setting back to 1 Watt when you move closer to other stations.

NOTE: By default, when you change to channel 16, the radio automatically boosts the power to 25 Watts. Be sure to change the power back to 1 Watt if you are not making an emergency transmission.

Some channels limit the power of transmission to 1 Watt so that there is less interference between boaters attempting to use the channel at the same time. If you switch to one of these channels, the radio changes back to 1 Watt automatically. See the channel list on page 57 for a list of power-restricted channels.

Choosing Triple Watch or Dual Watch

In Triple Watch mode, the radio briefly checks channels 16 and 9 every two seconds. In Dual Watch mode, the radio checks channel 16 only. Generally, Triple Watch is used in areas where channel 9 is used as a hailing frequency, while Dual Watch is used in areas where channel 16 is used for distress and hailing. Your radio comes set to use Triple Watch; if you want to use Dual Watch instead, you will have to select it in the setup:

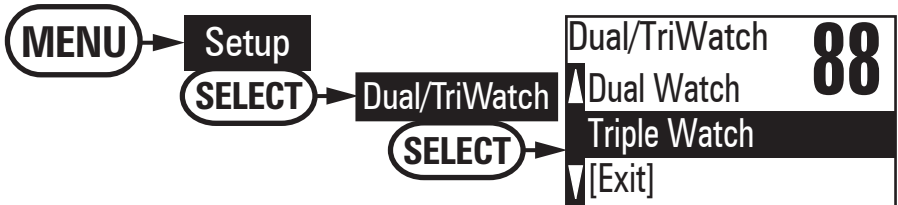

1. Press the **MENU-PA** button to display the menu.
2. Select *Setup* and then *Dual/Tri Watch*.
3. Highlight *Dual Watch* and press the **SELECT** button. The radio activates the new setting and returns to the *Setup* menu.
4. To reactive Triple Watch, repeat the procedure described above, but choose *Triple Watch* in step 3.

Changing display and sound options

Contrast

The UM425 display has 10 levels of contrast. To adjust the contrast, press the **MENU-PA** while the radio is idle. Select *System* and then *Contrast*. Use the **CHANNEL UP** and **CHANNEL DOWN** buttons to change the contrast to your desired level then press the **SELECT** button.

To restore the default contrast setting, turn the radio off. Press the **MENU-PA** button and hold it in while you turn the radio on.

Lamp adjust

The UM425 has 10 brightness levels on the display backlight. To adjust the brightness, press the **MENU-PA** button while the radio is idle. Select *System* and then *Lamp Adjust*. Use the **CHANNEL UP** and **CHANNEL DOWN** buttons to change the brightness to your desired level then press the **SELECT** button.

Turning the key beep on and off

Key beep is the tone that sounds when you press a key or a button. To turn off the key beep, press the **MENU-PA** while the radio is idle. Select *System* and then *Key Beep*. Choose *Off* to turn off the key beep then press the **SELECT** button.

Setting the GPS position manually

If the radio is not receiving valid GPS data, the radio displays *Input Position*. Follow the steps below to manually input your position.

NOTE: Be certain any manually-entered position is correct. If you enter the wrong position and then make a DSC distress call, you will be telling the Coast Guard to look in the wrong place.

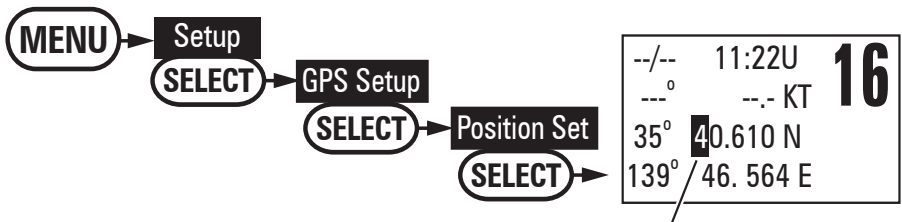

Use the up and down arrows to adjust each of the values in turn.

1. Display the menu and choose the *Setup* sub-menu.
2. Select *GPS Setup* and then choose *Position Set*.
3. The cursor highlights the hour. Use the **CHANNEL UP** and **CHANNEL DOWN** buttons to set the displayed hours to match coordinated universal time (UTC, also call Greenwich Mean Time and Zulu Time). When the display matches UTC time, press the **SELECT** button.
4. The cursor moves to highlight the minutes. Use the **CHANNEL UP** and **CHANNEL DOWN** buttons to adjust the minutes and press the **SELECT**-button.
5. The cursor moves to highlight the degrees latitude. As you update each value, the cursor moves to the next value in turn. At each number, use **CHANNEL UP** and **CHANNEL DOWN** buttons to adjust the number and press the **SELECT** button.

When you have entered the last value, the radio returns to the *GPS Setup* menu.

Using Digital Selective Calling (DSC) Features

What is DSC?

Digital Selective Calling or DSC is a standard that allows you to call other stations using their unique identification code (the Maritime Mobile Service Identity or MMSI number), just like you would call a phone number. To call another station, just enter that station's MMSI number and choose the voice channel you want to talk on. The radio uses channel 70 to transmit your MMSI number to the other station along with the voice channel you requested. If the other station accepts your call, both radios automatically switch to the requested voice channel so you can talk to the other station.

DSC provides a system for automated distress calls. At the touch of a button, the radio can transmit your MMSI number, the nature of your distress, and your current position based on data from your GPS receiver. The radio repeats the distress call every few minutes until it receives an acknowledgement.

The DSC standard dedicates a VHF channel—channel 70—to digital transmissions only. Since digital transmissions require less bandwidth voice transmissions, channel 70 avoids the problems of busy voice channels.

Advanced DSC features

The UM425 supports the following DSC features:

Feature	Menu Item	Function
Individual Call	Individual	Contact another vessel from your directory.
Group Call	Group	Contact all vessels that share your group MMSI code.
All Ships Call	All Ships	Broadcast to all vessels within range (used for safety or advisory messages.)
Position Request	POS Request	Request the current location of another vessel.
Position Send	Position Send	Transmit your current location to another vessel.
Test Call	Test	Make sure your radio is working and configured correctly
Name and MMSI Directory	Directory	Store a list of 20 names and MMSI identification codes for DSC calls.
Standby Mode	Standby	Automatically respond to all DSC calls with an "Unavailable" status.
Received Call Log	Receive Log	Display the last 10 distress calls received by the radio and the last 20 general calls.

Getting an MMSI number

In order to use DSC features, you must be assigned an MMSI number and program that number into your radio. There are two kinds of MMSI numbers: individual numbers for use by single boats and group numbers for use by fleets, boating organizations, event coordinators, etc.

You can get more information on MMSI numbers at these resources:

- The dealer where you purchased the radio
- **To Obtain an MMSI Code in Australia**
The Australian Maritime Safety Authority allocates MMSI. To apply for an MMSI complete the MMSI Application form available for download via www.amsa.gov.au/mmsi . This page has important information about MMSI and DSC radio.
- **To Obtain an MMSI Code in NZ**
To obtain an MMSI for a VHF Recreational Radio contact the Ministry of Economic Development - Radio Spectrum Management at; Email: info@rsm.govt.nz or free phone 0508 776 4630.
The DSC radio owner should indicate they are seeking an MMSI for a VHF Recreational Radio and would then need to supply the following;
 - Name
 - VHF Call sign
 - Vessel Name
 - Vessel DetailsThe MMSI given will then be a unique number which will conform to the ITU format.

Entering MMSI numbers

Individual or user MMSI number

Follow the steps below to enter your individual or user MMSI number into the radio:

NOTE: Be sure you have the correct User MMSI number before entering it in the radio. The radio only allows you to enter the user MMSI once. If you need to enter the User MMSI number for the second time, contact customer service (see page 66 for contact information).

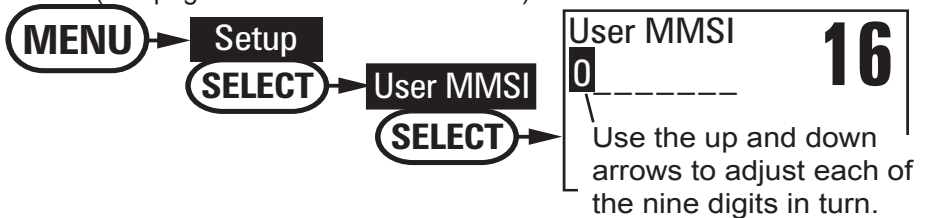

1. Display the menu and choose the *Setup* sub-menu.
2. Select *User MMSI*. If an MMSI number was entered previously, the screen displays it.

3. Use the **CHANNEL UP** and **CHANNEL DOWN** buttons to change the first of the nine digits; the **CHANNEL UP** button increases the number and the **CHANNEL DOWN** button decreases the number.
4. When the first digit is correct, press the **SELECT** button. The cursor moves to the next digit. Enter the remaining eight digits of the MMSI number in the same way.
5. When the ninth digit is correct, press the **SELECT** button. The radio displays the new MMSI number and asks you to confirm.

NOTE: Be sure you entered the number correctly before confirming the entry. You can only save the user MMSI once. If the radio displays *Cannot change over 1 time*, contact customer service (see page 66 for contact information).

6. To save this MMSI number, select *Yes*. To cancel this MMSI number, select *No*. The radio returns to the *Setup* menu.

Group MMSI number

You can change the group MMSI number as often as you want. Follow the steps below to enter a group MMSI number into the radio:

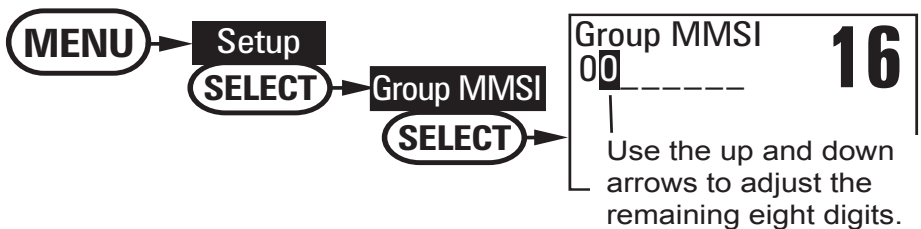

1. Display the menu and choose the *Setup* sub-menu.
2. Select *Group MMSI*. If a group MMSI number was entered previously, the screen displays it.
3. Group MMSI numbers always start with a 0, so that digit is already entered for you. Use the **CHANNEL UP** and **CHANNEL DOWN** buttons to change the second of the nine digits; the **CHANNEL UP** button increases the number and the **CHANNEL DOWN** button decreases the number.
4. When the second digit is correct, press the **SELECT** button. The cursor moves to the next digit. Enter the remaining seven digits of the MMSI number in the same way.

5. When the ninth digit is correct, press the **SELECT** button. The radio displays the new MMSI number and asks you to confirm.
6. To save this MMSI number, select *Yes*. To cancel this MMSI number, select *No*. The radio returns to the *Setup* menu.

Using the directory

The directory lets you store up to 20 MMSI numbers of other stations so you can call them quickly.

Follow the steps below to edit the MMSI numbers in your directory:

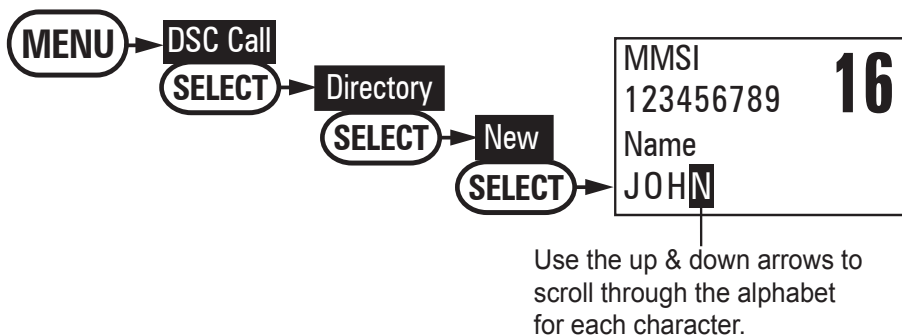

1. Display the menu and choose the *DSC Call* sub-menu.
2. Select *Directory*. The screen displays any previously-entered MMSI numbers and names.
3. To add a new MMSI number to the directory, select *New*.
4. The radio prompts you to enter the nine-digit MMSI number. Use the **CHANNEL UP** and **CHANNEL DOWN** buttons to change the first digit; the **CHANNEL UP** button increases the number and the **CHANNEL DOWN** button decreases the number.
5. When the first digit is correct, press the **SELECT** button. The cursor moves to the next digit. Enter the remaining eight digits of the MMSI number in the same way.
6. When the ninth digit is correct, press the **SELECT** button.
7. The radio prompts you to enter a name for this MMSI number; the name is what you will see in the directory list. Each name can be up to 12 characters. Use the **CHANNEL UP** and **CHANNEL DOWN** buttons to change the first character. The channel buttons scroll through the available characters according to the following table:

Table 6 - Character and text entry order

CHANNEL UP button	CHANNEL DOWN button
Capital letters (A through Z)	One blank space
Lower-case letters (a through z)	Numbers (0 through 9)
Punctuation (/ ' + -)	Punctuation (/ ' + -)
Numbers (0 through 9)	Lower-case letters (a through z)
One blank space	Capital letters (A through Z)

8. When the first character is correct, press the **SELECT** button. The cursor moves to the next character. Enter the remaining 11 characters of the name. If the name is shorter than 12 characters, press and hold the **SELECT** button to complete the name entry. (If you press and hold the **SELECT** button without entering a name, the radio uses the MMSI number in the directory list.)
9. When you finish entering the name, the radio displays the new MMSI number and name and asks you to confirm. To save this directory entry, select *Yes*; to cancel this directory entry, select *No*. The radio returns to the directory list.
10. To change an existing directory entry, select the entry you want to change.
11. To delete the directory entry, select *Delete*. To edit the code, select *Edit*, then use **CHANNEL UP** and **CHANNEL DOWN** buttons to edit the MMSI number and the name.
12. When you are satisfied with the directory list, select *Exit* to close the menu screen.

Making DSC Calls

There are essentially four different types of DSC voice calls:

Call type	What it does	When to use it
Distress	Alerts all stations that you need assistance and sends them your current position.	In an emergency only.
Individual	Calls a single station using the User MMSI.	Any time you want to talk to another station.
Group	Calls all the stations that have the same Group MMSI as yours.	Any time you want to talk with the whole group you are traveling with at the same time.
All ships	Calls all stations in range of your radio.	Safety warnings (e.g., debris in the water) or an urgency situation.

For examples of how you might use different call types, see the diagram below:

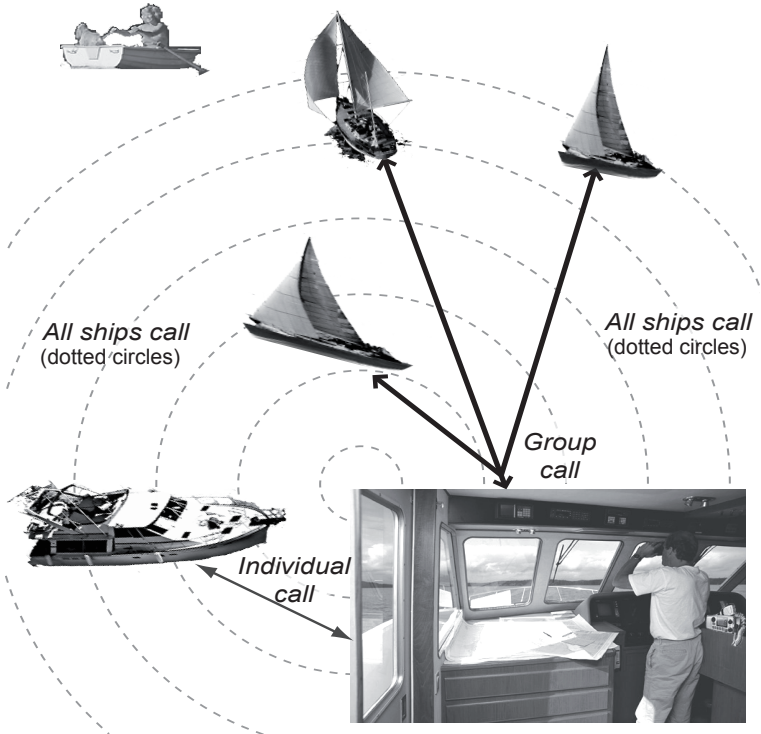

Suppose you are coordinating safety for a sailboat race. Before the race starts, you instruct all the racers to enter your group MMSI number into their radios. During the race:

- Throughout the race, you use group calling to update the racers on the time, race status, and any course corrections.
- A power boat full of spectators comes a little too close to the race path. You use individual calling to contact the power boat and advise them to stay clear of the race.
- You see a rowboat entering the area, but since it doesn't have a radio, you can't communicate with the rowboat. You use all ships calling to alert all the other boats in the area of the possible danger.

Calling a single station (*Individual Call*)

To call a single station with DSC, follow the steps below:

1. Press the **MENU-PA** button to display the menu.
2. Choose the *DSC Call* sub-menu, then select *Individual*.
3. The radio displays the names listed in your directory; use **CHANNEL UP** and **CHANNEL DOWN** buttons to highlight the directory entry you want to call and press the **SELECT** button.

If you want to call a station that is not in your directory, select *Manual*. The radio prompts you to enter the MMSI number you want to call. Enter the MMSI number the same way you enter directory entries (see page 27) Enter all nine digits and press the **SELECT** button.

4. The radio prompts you to select a response channel. Use **CHANNEL UP** and **CHANNEL DOWN** buttons to scroll through the available channels. When you reach the channel you want to use for a response, press the **SELECT** button.
5. The radio displays the MMSI number you are about to call and asks you to confirm. If you want to call the displayed MMSI number, select *Send*. To cancel the call, select *Cancel*.
6. The radio automatically switches to channel 70 to transmit the call request.

- When the other station accepts the call, both radios switch to the selected response channel for voice transmission.
- If the other station cannot respond on the channel you selected, the radio displays *Not support CH*.

Calling a particular group of stations (*Group Call*)

Group calling calls all the stations that share your group MMSI. You must have a group MMSI programmed into the radio to make a group call, and the stations (boats) you are calling must have this same group MMSI programmed into their radios.

1. Press the **MENU-PA** button to display the menu.
2. Choose the *DSC Call* sub-menu and select *Group*.
3. The radio prompts you to select a response channel. Use the **CHANNEL UP** and **CHANNEL DOWN** buttons to scroll through the available channels. When you reach the channel you want to use for a response, press the **SELECT** button.
4. The radio asks you to confirm the call. Select *Send* to continue with the call or select *Cancel* to cancel the call.
5. The radio switches to channel 70 to transmit the call request then automatically switches to the selected response channel.

Calling all stations (*All-Ships Call*)

All ships calling contacts all DSC radios within range of your boat. You should only use all ships calling in the event of a Safety warning (such as debris in the water) or to request assistance in an *Urgency* (any situation where your vessel has a serious problem but is not yet in distress).

1. Open the menu and select the *DSC Call* sub-menu.
2. Select *All Ships*, and then choose whether this is an *Urgency* call or a *Safety* call.
3. The radio asks you to confirm the call. Select *Send* to continue with the call or select *Cancel* to cancel the call.
4. The radio automatically switches to channel 70 to transmit the call request then automatically switches to channel 16, the designated response channel for all-ships calling.

Making an automatic distress call

If you have programmed your MMSI number, the UM425 can transmit an automated distress call with your current location and nature of the distress. The radio then monitors the channel 16 for a response and repeats the distress call every few minutes until it receives an acknowledgement.

To send an automatic distress call, press and hold the DISTRESS button for three seconds. If no MMSI number has been programmed, the radio prompts you to enter your MMSI number.

If you want to include the nature of your distress in the distress call, use the distress procedure below:

1. Press the **DISTRESS** button.
2. The radio displays the list of distress conditions; use the **CHANNEL UP** and **CHANNEL DOWN** buttons to highlight the nature of your distress, then press and hold the **DISTRESS** button for three seconds.
 - Undesignated
 - Fire
 - Flooding
 - Collision
 - Grounding
 - Capsizing
 - Sinking
 - Adrift
 - Abandoning
 - Piracy/Armed
 - Overboard
3. If no MMSI number has been programmed, the radio prompts you to enter your MMSI number.

Canceling an automatic distress call

While the radio is waiting for a response, it gives you the option of canceling the call. To cancel the distress call, highlight *Cancel* and press the **SELECT** button.

Receiving a DSC call

If your radio receives an individual DSC call from another station, it sounds an incoming call tone and displays the name or MMSI number of the station calling you. To respond to the call, select *Send: Able-Comply*; the radio sends an acknowledgement and automatically switches to the designated response channel. To reject the call, select *Send: Unable-Comply*; the radio advises the other station that you are unable to respond to the call.

If the DSC request contains a response channel that you are not allowed to use, the radio displays *Not Support CH*; your only response option is *Send: Unable-Comply*.

If the radio receives a group or all ships call, it sounds an incoming call tone and automatically switches to the designated response channel.

Receive log

Just like your telephone's caller ID list, your radio keeps track of the calls you receive but do not answer. The receive log is useful if you have been off your boat or away from your radio and want to see who has tried to contact you. The radio displays the last 10 distress calls and the last 20 non-distress calls that it received.

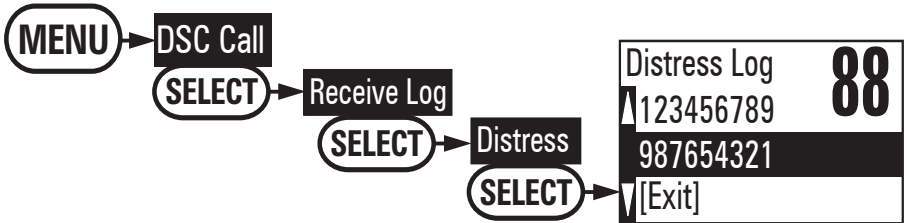

1. Press the **MENU-PA** button to display the menu.
2. Choose the *DSC Call* sub-menu and then select *Receive Log*.
3. Select *Distress* to see the last 10 distress call received by the radio. Select *Other* to see the last 20 normal calls received by the radio, then choose from *Individual*, *Group* or *All Ships* calls.
4. Calls are listed in the order they were received, with the newest call shown first. The display blinks if there are new calls you have not reviewed.
5. Select the call you want to see the details of. Use **CHANNEL UP** and **CHANNEL DOWN** buttons to see all of the information. The log displays different information depending on type of call received. See the table below for the information stored for each type of call:

Table 7 - Receive Log

DSC Call Type	Receive Log Information
Distress	MMSI (or name), position, time, nature code.
Distress Acknowledge	MMSI (or name), distress MMSI, position, time, nature code.
Distress Relay	MMSI (or name), distress MMSI, position, time, nature code.
Distress Relay Acknowledge	MMSI (or name), distress MMSI, position, time, nature code.
Geographical	MMSI (or name), category code.
All Ships	MMSI (or name), category code.
Group	MMSI (or name), category code.
Individual	MMSI (or name), category code.
Individual Acknowledge	MMSI (or name), Completed/Unattended, category code.
Test	MMSI (or name), category code.
Test Acknowledge	MMSI (or name), category code.
Pos Reply	MMSI (or name), position, time, category code.
Pos Request	MMSI (or name), category code.
Pos Send	MMSI (or name), position, time, category code.

6. Press the **MENU-PA** button to exit the detail screen and return to the log menu.
7. From the log menu, select *Exit* to close the receive log and return to the mode you were in.

Returning a call

You can return individual calls directly from the receive log. From the call detail screen, press the **CHANNEL DOWN** button until *Call Back* appears at the bottom of the display. Press the **SELECT** button to return that station's call.

Making Test Calls (Test)

You can use the *test call* feature to make sure your radio is working and configured correctly. To avoid overloading coastal receiving stations, you should limit test calls to these stations to once a week.

NOTE: Many coastal stations have specific frequencies and MMSI numbers you should use for making test calls. Be sure to check with the coastal station before making a DSC test call.

1. Press the **MENU-PA** button to display the menu.
2. Choose the *DSC Call* sub-menu, then select *Test*.
3. The radio displays the names listed in your directory; use the **CHANNEL UP** and **CHANNEL DOWN** buttons to highlight the directory entry you want to send a test call to and press the **SELECT** button.



If you want to send a test call to a station that is not in your directory, select *Manual*. The radio prompts you to enter the MMSI number you want to call. Enter the MMSI number the same way you enter directory entries (see page 27). Enter all nine digits and press the **SELECT** button.

4. The radio displays the MMSI number you are about to call and asks you to confirm. If you want to call the displayed MMSI number, select *Send*. To cancel the call, select *Cancel*.
5. The radio automatically switches to channel 70 to transmit the test call request, then switches back to the last-used channel.

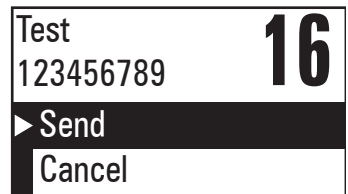

- When the other station acknowledges the test call, the radio displays an acknowledgement screen.

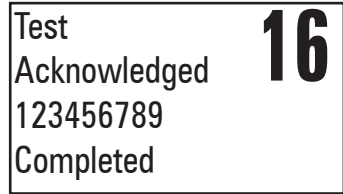

Receiving a test call

When another station sends you a test call, the radio displays the test request screen:

To acknowledge the test call, select *Reply*

To reject the test call, select *Cancel*.

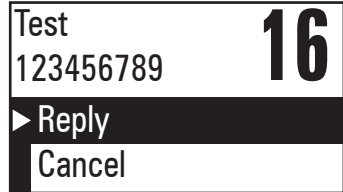

Enabling automatic test call reply

If you want the radio to automatically reply to all test call, you can enable automatic test call reply.

- Press the **MENU-PA** button to display the menu.
- Select *Setup* and then *Test Reply*.
- Highlight *Auto* and press the **SELECT** button. The radio will automatically send an acknowledgement when it receives a test call.



- To disable automatic test call reply, repeat the steps above and select *Manual*.

Requesting another station's position (POS Request)

Anytime you need to know where another boat currently is—to find your boating partners, to respond to a request for assistance, etc.—you can send a position request to their radio:

1. Press the **MENU-PA** button to display the menu.
2. Choose the *DSC Call* sub-menu, then select *POS Request*.
3. The radio displays the names listed in your directory; use **CHANNEL UP** and **CHANNEL DOWN** buttons to highlight the directory entry you want to contact and press the **SELECT** button. If you want to contact a station that is not in your directory, select *Manual*. The radio prompts you to enter the MMSI number you want to call. Enter the MMSI number the same way you enter directory entries (see page 27). Enter all nine digits and press the **SELECT** button.
4. The radio displays the MMSI number you are about to contact and asks you to confirm. If you want to request the position of the displayed MMSI number, select *Send*. To cancel the request, select *Cancel*.
5. When the other station responds, the radio displays the MMSI number, the longitude, and the latitude of the other station. If your radio is connected to a chartplotter through the NMEA OUT connection (see page 48), the position information will also be displayed on the plotter screen.
6. If the other station does not have valid GPS data, the radio displays *No Position*.

Receiving a position request (Position Reply)

When another station requests your current position, the radio displays the following screen:

To send your current position to the other station, select *Reply*; the radio transmits your latitude and longitude to the other station. If you select *Reply* but the radio does not have valid GPS data, it transmits the reply code with *No Position*.

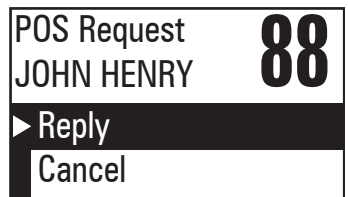

To reject the position request, select *Cancel*.

Enabling automatic position reply

If you want the radio to automatically transmit your current position whenever it receives a position request, you can enable automatic position reply. Most boaters activate automatic position reply for safety reasons or because they subscribe to a marine towing service. Sometimes—for example, in some competitive situations—you may not want other stations to get your position without your manual confirmation

1. Press the **MENU-PA** button to display the menu.
2. Select *Setup* and then *POS Reply*.
3. Highlight *Auto* and press the **SELECT** button. The radio will automatically transmit your position when it receives a position request.
4. To disable automatic position reply, repeat the steps above and select *Manual*.

Sending your own position (Position Send)

If your radio is connected to a GPS receiver, you can send your boat's position to someone else. If you are requesting assistance or using an all ships call to give a safety warning, you can send your current position so other stations know where you are:

1. Press the **MENU-PA** button to display the menu.
2. Choose the *DSC Call* sub-menu, then select *Position Send*.
3. The radio displays the names listed in your directory; use **CHANNEL UP** and **CHANNEL DOWN** buttons to highlight the directory entry you want to contact and press the **SELECT** button. If you want to contact a station that is not in your directory, select *Manual*. The radio prompts you to enter the MMSI number you want to call. Enter the MMSI number the same way you enter directory entries (see page 27). Enter all nine digits and press the **SELECT** button.
4. The radio displays the MMSI number you are about to contact and asks you to confirm. If you want to transmit your position to the displayed MMSI number, select *Send*. To cancel the transmission, select *Cancel*.
5. The radio transmits your MMSI number, your longitude, and your latitude to the other station.

Putting the radio into standby

If you are leaving your radio or do not wish to answer any DSC calls, you can put your radio in standby mode. If your radio receives an individual call, it will automatically respond with a message that indicates your radio is currently "Unattended" on the display of the calling radio. Follow the steps below to put your radio in standby:

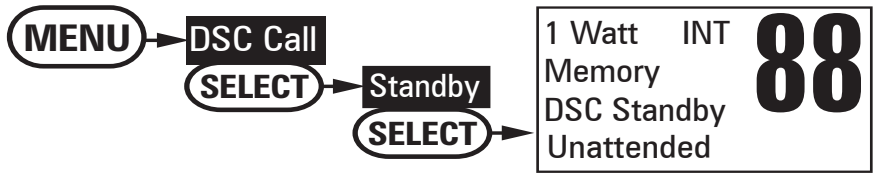

1. Display the menu and choose the *DSC Call* sub-menu.
2. Select *Standby* to place your radio in standby mode. The radio displays the standby screen, above.
3. To cancel standby and return to the mode your radio was in, press any button.

Disabling automatic channel switching

If you are involved in a bridge-to-bridge call, you may not want the radio to automatically switch channels when it receives a DSC call. In cases like this, you can disable automatic channel switching. If you receive an individual call, the radio will respond with an unattended code, just as if the radio were in Standby.

1. Press the **MENU-PA** button to display the menu.
2. Select *Setup* and then *Auto CH SW*.
3. Highlight *Off* and press the **SELECT** button. The radio will not automatically switch channels until you reactivate this feature.

NOTE: Use this feature with caution. Deactivating automatic switching and then forgetting it can make it hard for you to receive DSC calls.

Renaming Channels

If you discover that a marine radio channel has a different common name in your local area, you can change the name of that channel to make it easier for you to use (see the channel list on page 57 for the default channel names). To rename a channel, follow the steps below:

1. Display the menu and choose the *Setup* sub-menu.
2. Select *Channel Name*. The screen displays the list of channels.
3. Use **CHANNEL UP** and **CHANNEL DOWN** buttons to highlight the channel you want to change and press the **SELECT** button.
4. Select *Rename* to enter a new name for this channel. The radio prompts you to enter a new name for this channel. Each name can be up to 12 characters. Use the **CHANNEL UP** and **CHANNEL DOWN** buttons to change the first character. (See *Table 6 Character and text entry order* on page 28 for the available characters and the order in which they scroll).
5. When the first character is correct, press the **SELECT** button. The cursor moves to the next character. Enter the remaining 11 characters of the name. If the name is shorter than 12 characters, press and hold the **SELECT** button to complete the name entry.
6. When you finish entering the name, the radio displays the new channel name and asks you to confirm. To save this new channel name, select *Yes*; to cancel the change, select *No*. The radio returns to the channel list.
7. To restore a channel back to its original name, select the channel and choose *Default*.
8. When you are satisfied with the channel list, select *Exit* to close the menu screen.

Installing the Hardware

Mounting the radio

The UM425 can sit at any angle in the mounting bracket so it can easily accommodate the best location. First, determine the best place to mount the radio. For optimum performance, find a location that can:

- Properly support the weight of the radio, approximately 2 pounds or 0.9 kilograms. You may need to use some type of anchor with the mounting screws to hold the radio, depending on the surface.
 - Keep the battery leads as short as possible.
 - Keep the antenna lead-in wire as short as possible.
 - Allow free air flow around the heat sink on the rear of the radio.
 - Avoid interference with the ship's compass.
1. Install the radio into the mounting bracket, and connect the **power cable** and **accessory cable**.

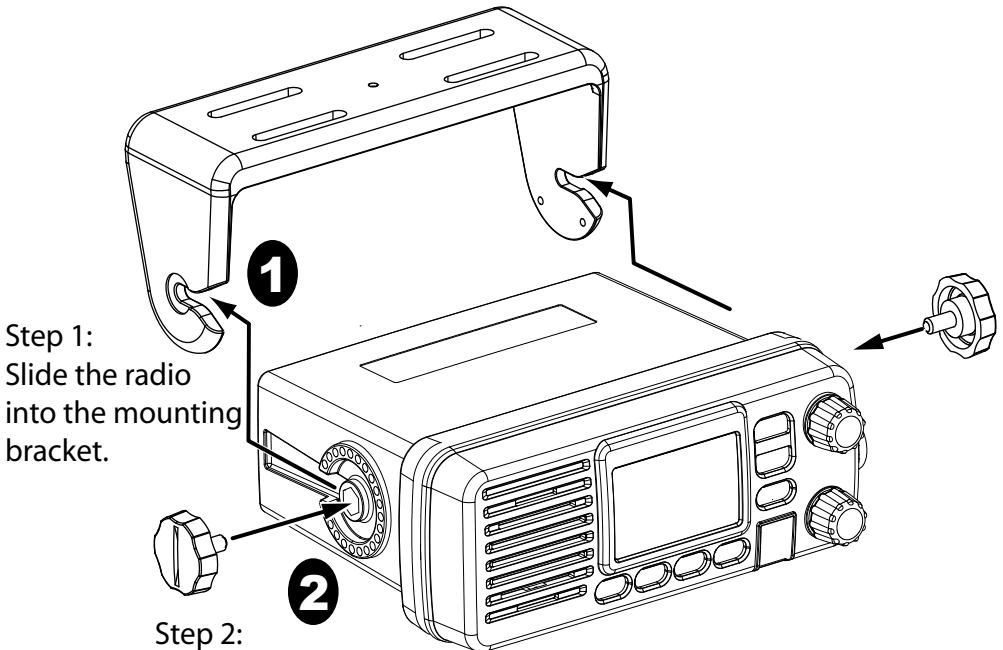

Step 1:
Slide the radio
into the mounting
bracket.

Step 2:
Tighten the mounting knobs
to secure the radio in place.

2. Position the radio into the desired location. Mark the edges of the bracket on the mounting surface.
3. Remove the mounting bracket drill template from the back of the manual, and use the template to mark the drill holes on the mounting surface.
4. Drill the holes for the mounting bracket; be sure to follow any special requirements of the mounting surface.
5. Remove the bracket from the radio, and use the mounting hardware to secure the bracket to the mounting surface.

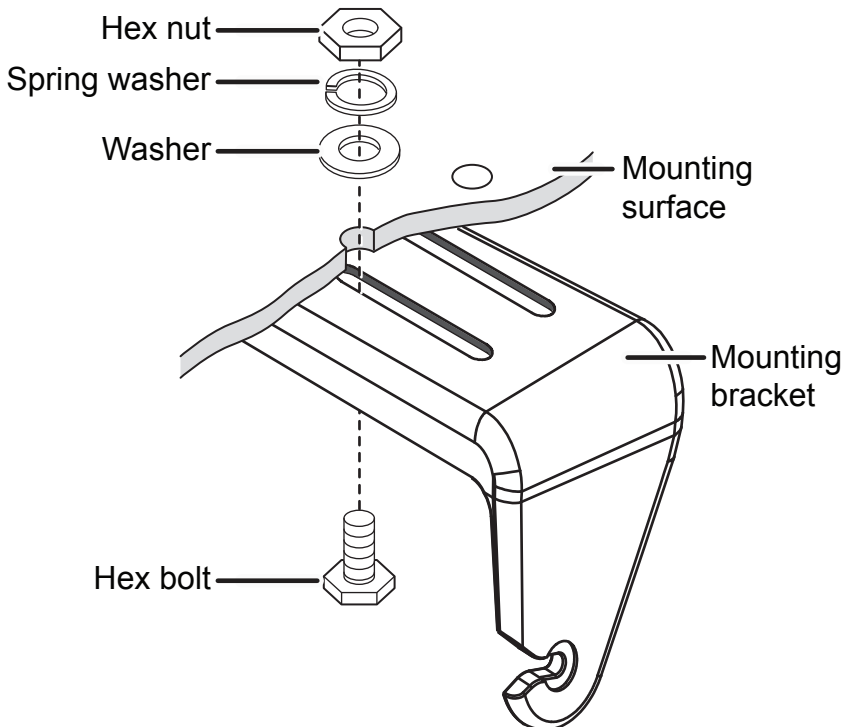

6. Install the radio back into the mounting bracket.

Connecting the radio

To operate correctly, your UM425 requires two electrical connections:

- providing it with power from the boat's electrical system
- connecting a VHF-FM marine antenna to the antenna connector

Power supply requirements	VHF antenna requirements
Nominal 13.8 VDC power supply with a negative ground (10.8 VDC to 15.6 VDC). Power leads should be kept as short as possible. A direct connection to the power supply is ideal. Minimum of #14 AWG copper wire for extensions up to 6m, 12 AWG wire for extensions from 6m to 10m, or 10 AWG wire for extensions from 10 to 18m	Male PL-259 connector 50 Ω impedance Minimum 1.2m, 3 dB rated antenna for sailboats or 2.4m, 6dB rated antenna for powerboats Minimum RG-58 lead-in wire for antenna leads up to 6m to 10m, RG-8X for antenna leads from 6m to 10m, or RG-8U for antenna leads from 10m to 18m.

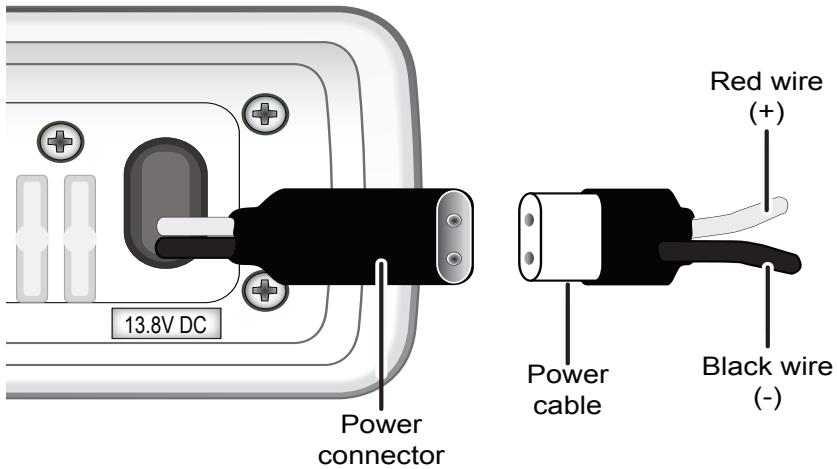

1. Connect the BLACK wire of the included **power cable** to the NEGATIVE (-) side of your power source.
2. Connect the RED wire of the included **power cable** to the POSITIVE (+) side of your power source.
3. Connect the **power cable** to the **power connector** on the back of the UM425. (The power connector only fits one way.)

NOTE: To extend the life of the radio, use waterproof tape to seal electrical connections.

4. Install your antenna according to the manufacturer's instructions.
5. See Antenna Selection and Installation on page 65 for more details.
6. Connect the PL-259 connector from the antenna lead-in wire to the SO238 connector labeled **ANTENNA** on the back of the UM425.

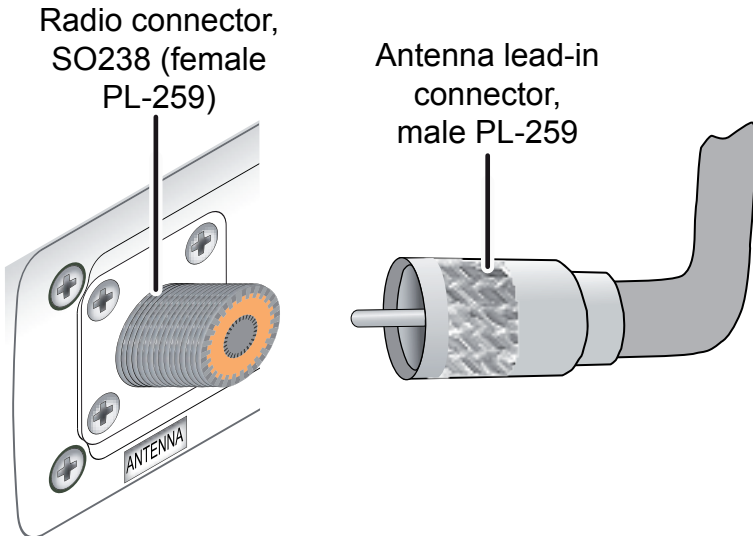

Connecting accessories

Connecting to a GPS receiver

If you connect the radio to a GPS receiver, the radio can automatically transmit your current position during an automated distress call or during a normal DSC call.

The UM425 supports a standard NMEA0183 input from a GPS receiver. Follow the steps below to connect the UM425 to your GPS receiver:

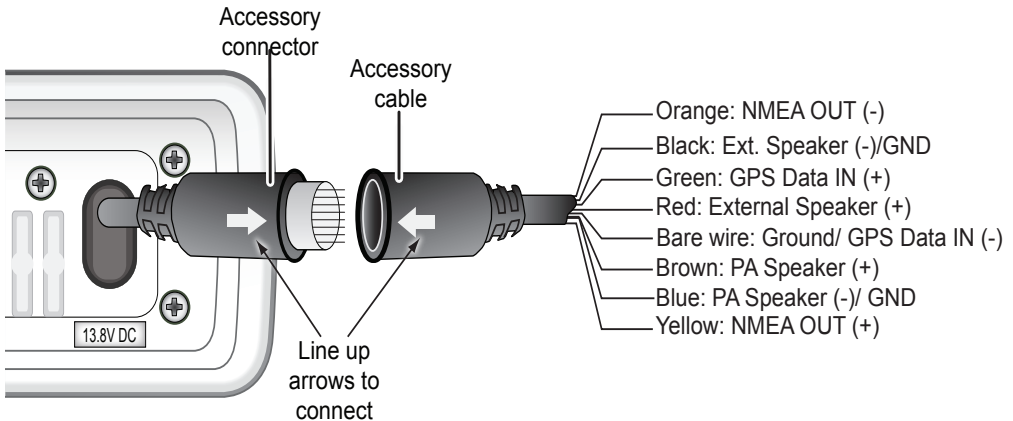

1. Disconnect the **accessory cable** from the accessory connection on the radio.
2. Connect the BARE wire of the included **accessory cable** to the GROUND WIRE on your GPS receiver.
3. Connect the GREEN wire of the included **accessory cable** to the GPS DATA OUTPUT WIRE on your GPS receiver. On page 46 is a table of common GPS receivers and the proper connections:

NOTE: If not using the accessory connector make sure the cap is firmly secured.

Table 8 - Common GPS receivers and connections

GPS Manufacturer	Model Number(s)	GPS NMEA0183 OUTPUT Wire Color (Connect to GREEN WIRE on UM425)	Ground Wire Color (connect to BARE WIRE on UM425)
Furuno	GP1650, GP1850	White	Black
Furuno	GP30, GP36	White	Blue
Garmin	Fixed Mount Models	Blue	Black
Garmin	Portable Models	Brown	Black
JRC	100 Series	Green	Black
JRC	200 Series	White	Black
JRC	GPS500	Yellow	Green
Lowrance / Eagle	Fixed Mount Models	White	Black
Lowrance / Eagle	Portable Models	Orange	Black
Magellan	Fixed Mount Models	Gray	Black
Magellan	Portable Models	Orange	Black
Northstar	All Models	Yellow	Black
RayMarine	420	Yellow	Brown
RayMarine	520 / 620	Blue	Brown
RayMarine	RL Series	White	Brown
Simrad	All Models	White	Brown
Sitex	Neptune, Nautilus	Gray	Brown
Standard	CP150 / CP150C	Green	Yellow

4. Be certain all wire connections are secure and that all open wires are adequately covered.
5. If you are finished connecting all external accessories, line up the arrows on the side of the **accessory cable** and connector and connect the accessory cable to the **accessory connector** on the back of the UM425.

NOTE: To extend the life of the radio, use waterproof tape to seal electrical connections.

When the GPS receiver is correctly connected, the display shows *GPS Data OK*. If there is a problem with the GPS connection, the display shows *Check GPS*. When the display shows *GPS Data OK*, press the **SELECT** button to open the GPS status screen and see detailed GPS data:

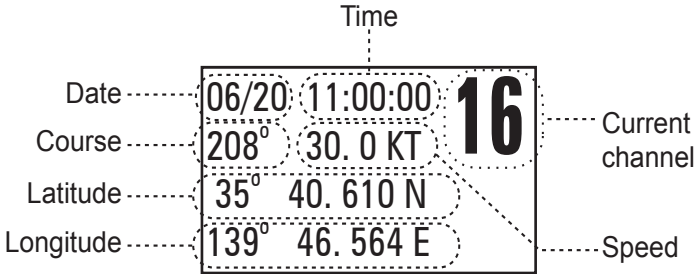

Configuring the GPS

If the radio is receiving valid GPS data, it will automatically set the clock to your local time based on the GPS location. You can adjust your local time forward or back one hour if necessary (for example, if you are close to the border of a time zone); you can also adjust for Daylight Savings Time.

Follow the steps below to adjust the time:

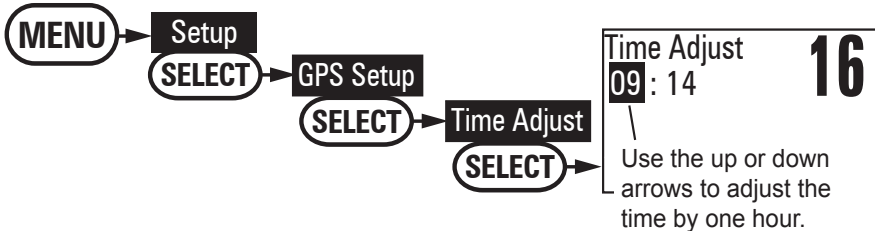

1. Display the menu and choose the *Setup* sub-menu.
2. Select *GPS Setup* and then choose *Time Adjust*.
3. The display shows your current local time. To adjust the time forward one hour, use the **CHANNEL UP** button. To adjust the time back one hour, use the **CHANNEL DOWN** button. Press the **SELECT** button when you are finished.
4. The display prompts you to confirm the setting: choose *Set* to save the new time or *Cancel* to exit time setup without saving. The radio returns to the *GPS Setup* menu.
5. If your local area observes Daylight Savings Time, highlight *Daylight Save* and press the **SELECT** button.

6. If Daylight Savings Time is currently in effect, select *On*. If Daylight Savings Time is not currently in effect, select *Off*.
7. Press the **SELECT** button. The radio activates the new time setting and returns to the *GPS Setup* menu.

Connecting to a chartplotter

The UM425 provides a standard NMEA0183 GPS output that you can connect to a chartplotter. When it receives another boat's position data in a DSC call, the radio sends the position data to the chartplotter so you can see the location:

1. Disconnect the **accessory cable** from the accessory connection on the radio.
2. Connect the ORANGE wire of the **accessory cable** to the NEGATIVE (-) wire of your chartplotter's NMEA data INPUT.
3. Connect the YELLOW wire of the **accessory cable** to the POSITIVE (+) wire of your chartplotter's NMEA data INPUT.
4. Be certain all wire connections are secure and that all open wires are adequately covered.
5. If you are finished connecting all external accessories, line up the arrows on the side of the **accessory cable** and connector and connect the **accessory cable** to the **accessory connector** on the back of the UM425.

NOTE: To extend the life of the radio, use waterproof tape to seal electrical connections.

Connecting to an external speaker

You can use an external speaker to monitor the radio from a different part of your boat or in a noisy environment. If you adjust the **VOLUME-PWR** knob on the radio, it will also adjust the external speaker volume.

The UM425 supports an external speaker with the following specifications:

- Minimum impedance of 4 Ohms
- Minimum power handling of 10 Watts

1. Disconnect the **accessory cable** from the accessory connection on the radio.
2. Connect the BLACK wire of the **accessory cable** to the GROUND WIRE of your external speaker.
3. Connect the RED wire of the **accessory cable** to the POSITIVE (+) WIRE of your external speaker.
4. Be certain all wire connections are secure and that all open wires are adequately covered.
5. If you are finished connecting all external accessories, line up the arrows on the side of the **accessory cable** and connector and connect the **accessory cable** to the **accessory connector** on the back of the UM425.

NOTE: To extend the life of the radio, use waterproof tape to seal electrical connections.

Connecting to an external PA speaker

If you connect the radio to a PA speaker, you can use the PA feature to make announcements to other boats and people nearby.

The UM425 supports an external PA speaker with the following specifications:

- Minimum impedance of 4 Ohms
- Minimum power handling of 10 Watts

1. Disconnect the **accessory cable** from the accessory connection on the radio.
2. Connect the BLUE wire of the **accessory cable** to the GROUND WIRE of your PA system.
3. Connect the BROWN wire of the **accessory cable** to the POSITIVE (+) WIRE of your PA system.
4. Be certain all wire connections are secure and that all open wires are adequately covered.
5. If you are finished connecting all external accessories, line up the arrows on the side of the **accessory cable** and connector and connect the **accessory cable** to the **accessory connector** on the back of the UM425.

NOTE: To extend the life of the radio, use waterproof tape to seal electrical connections.

Using the PA feature

1. Press and hold the **MENU-PA** button for two seconds to activate the PA feature. The display shows *PA* in the upper right hand corner.
2. Press and hold the microphone **PUSH TO TALK** button. Speak clearly in your normal voice (you don't have to shout). Use the **VOLUME-PWR** knob on your UM425 to adjust the volume of the PA speaker.
3. Release the **PUSH TO TALK** button when you're finished talking.
4. To turn off the PA feature and return to the radio mode you were using, press and hold the **MENU-PA** button for two seconds again.



Maintenance and Troubleshooting

Due to its rugged design, the UM425 requires very little maintenance. However, it is a precision electronic instrument, so you should follow a few precautions:

- If the antenna has been damaged, you should not transmit except in the case of an emergency. A defective antenna may cause damage to your radio.
- You should arrange for periodic performance checks with your Uniden dealer.

Common questions

Problem	Things to Try
The radio won't power on.	Check the power connections. Check the fuse. Check the master battery switch and branch circuit that connect to the radio.
The radio won't transmit.	Make sure you are not in scan mode. Make sure you are not trying to transmit on a receive-only channel (see the channels and frequency tables starting on page 57). Make sure you are transmitting at the correct power level for this channel (see the channels and frequency tables starting on page 57). Make sure the duration of each transmission is less than 5 minutes.
Noise comes out of the speaker all the time	Adjust the squelch level; it is probably too low.
I can't hear anything (no volume) from the speaker.	Adjust the squelch level; it is probably too high.
I can transmit, but no one can hear me.	Check your UIC channel settings (see Setting the UIC channel mode (USA/CAN/INT) on page 12).
I can't read the display.	Adjust the contrast and backlight brightness level (see page 22)
The display is too bright at night.	Adjust the backlight brightness level. (see page 22)
I can't see any words on the display.	Reset the radio back to the default contrast level: turn off the radio; hold the menu key and turn it back on.

Problem	Things to Try
I'm not getting any GPS data on my display.	Make sure your GPS receiver is correctly connected (see Connecting to a GPS receiver). Make sure your GPS receiver is working properly. Make sure that your GPS receiver supports the NMEA parameters described in NMEA Operation on page 63.
I can't make Group DSC calls.	Make sure the Group MMSI was entered correctly.
Where can I find my radio's serial number?	Look on the bottom side of the radio
The radio won't let me enter my User MMSI. What do I do?	Contact customer service by visiting the customer support page on www.uniden.com.au or www.uniden.co.nz .

Engine Noise Suppression

Interference from the noise generated by the electrical systems of engines is sometimes a problem with radios. The UM425 has been designed to be essentially impervious to ignition noise and alternator noise. However, in some installations it may be necessary to take measures to further reduce the effect of noise interference. The UM425 radio DC battery wires, antenna lead, and accessory cables should be routed away from the engine and engine compartment, and from power cabling carrying high currents. In severe cases of noise interference, it may be necessary to install a noise suppression kit. Contact the dealer where you purchased the radio for more information.

Specifications

Table 9 - Radio specifications

(All specifications are subject to change without notice.)

General	
Controls	VOLUME-PWR, Squelch
Status Indicators	Transmit power, Scan mode, Triple Watch mode, Battery High, Battery low, USA, CAN, INT, Memory, GPS status and Channel Display
Display	LCD (Full Dot Matrix)
Buttons	16/9-Tri, Scan-Mem, Channel Up, Channel Down, Menu-PA, Select, 1/25W, and Distress.
Connectors	Antenna, accessory, and DC power
Size	H 66.6 mm x W 162.6 mm x L 128 mm (without Heat Sink) H 2.62 inches x W 6.40 inches x L 5.04 inches (without Heat Sink)
Weight	0.93kg (2.05 pounds)
Supply Voltage	Nominal 13.8V DC, negative ground (10.8 VDC to 15.6 VDC)
Standard Accessories	Mounting bracket and hardware, DC power cable, microphone hanger, spare fuse, accessory cable
Antenna Impedance	50 Ω nominal
Microphone	Rugged 2 k Ω condenser mic element with coiled cord
Speaker	45 mm (1.77 inch), 8 Ω
Operating Temperature Range	-15 °C to + 55 °C (+5 °F to +131 °F)
Shock and Vibration	Meets or exceeds EIA standards, RS152B and RS204C

Specifications

Transmitter	
Power Output	1 watt or 25 watt (user selectable)
Power Requirement	25 watts output: 6A@13.8V DC
Modulation	±5 kHz deviation
Hum and Noise Signal-to-Noise	45 dB with 3 kHz deviation with 1000 Hz modulating frequency (nominal)
Audio Distortion	Less than 8% with 3 kHz deviation with 1000 Hz modulating frequency
Spurious Suppression	-45 dBm @ Hi, -55 dBm @ Lo
Output Power Stabilization	Built-in automatic level control (ALC)
Frequency Range	156 to 158 MHz
Frequency Stability	±1.5kHz @ -15°C to + 55°C
Receiver	
Frequency Range	156 to 162 MHz
Sensitivity	0.25 µV for 12 dB SINAD
Circuit	Dual Conversion Super Heterodyne PLL (Crystal for DSC)
Squelch Sensitivity	0.2 µV Threshold
Spurious Response	75 dB
Adjacent Channel Selectivity	78 dB @ ±25 kHz
Audio Output Power	2.5 watts (10% Distortion, 8 Ω load)
Power Requirement	400 mA @ 13.8V DC at squelched, 1000 mA @ 13.8V DC at maximum audio output
IF Frequencies	1st 41.925 MHz, 2nd 455 kHz (1st 21.7 MHz, 2nd 455 kHz for DSC)

Channel and frequencies

Table 10 - International Channel Frequencies and Channel Tag

Ch No.	RX Freq	TX Freq	Status	Full Name
1	160.6500	156.0500	Duplex	Marine operator
2	160.7000	156.1000	Duplex	Marine operator
3	160.7500	156.1500	Duplex	Marine operator
4	160.8000	156.2000	Duplex	Marine operator
5	160.8500	156.2500	Duplex	Marine operator
6	156.3000	156.3000	Simplex	Inter-ship safety
7	160.9500	156.3500	Duplex	Marine operator
8	156.4000	156.4000	Simplex	Commercial (ship-ship)
9	156.4500	156.4500	Simplex	Boater calling channel
10	156.5000	156.5000	Simplex	Commercial
11	156.5500	156.5500	Simplex	Vessel traffic system
12	156.6000	156.6000	Simplex	Vessel traffic system
13	156.6500	156.6500	Simplex	Bridge to bridge
14	156.7000	156.7000	Simplex	Vessel traffic system
15	156.7500	156.7500	Simplex, 1W	Environmental
16	156.8000	156.8000	Simplex	Distress, Safety, Calling
17	156.8500	156.8500	Simplex, 1W	Govt maritime control
18	161.5000	156.9000	Duplex	Port operation
19	161.5500	156.9500	Duplex	Commercial
20	161.6000	157.0000	Duplex	Port operation
21	161.6500	157.0500	Duplex	Port operation
22	161.7000	157.1000	Duplex	Port operation
23	161.7500	157.1500	Duplex	Marine operator
24	161.8000	157.2000	Duplex	Marine operator
25	161.8500	157.2500	Duplex	Marine operator
26	161.9000	157.3000	Duplex	Marine operator
27	161.9500	157.3500	Duplex	Marine operator
28	162.0000	157.4000	Duplex	Marine operator
60	160.6250	156.0250	Duplex	Marine operator
61	160.6750	156.0750	Duplex	Marine operator
62	160.7250	156.1250	Duplex	Marine operator
63	160.7750	156.1750	Duplex	Marine operator
64	160.8250	156.2250	Duplex	Marine operator
65	160.8750	156.2750	Duplex	Marine operator
66	160.9250	156.3250	Duplex	Marine operator
67	156.3750	156.3750	Simplex	Bridge to bridge
68	156.4250	156.4250	Simplex	Non commercial
69	156.4750	156.4750	Simplex	Non commercial
70	(156.5250	156.5250)	DSC Only	DSC

Table 10 - International Channel Frequencies and Channel Tag (cont'd)

Ch No.	RX Freq	TX Freq	Status	Full Name
71	156.5750	156.5750	Simplex	Non commercial
72	156.6250	156.6250	Simplex	Non commercial
73	156.6750	156.6750	Simplex	Port operation
74	156.7250	156.7250	Simplex	Port operation
75	156.7750	156.7750	Simplex, 1W	Port operation
76	156.8250	156.8250	Simplex, 1W	Port operation
77	156.8750	156.8750	Simplex	Port operation (ship-ship)
78	161.5250	156.9250	Duplex	Port operation
79	161.5750	156.9750	Duplex	Port operation
80	161.6250	157.0250	Duplex	Port operation
81	161.6750	157.0750	Duplex	Port operation
82	161.7250	157.1250	Duplex	Port operation
83	161.7750	157.1750	Duplex	Port operation
84	161.8250	157.2250	Duplex	Marine operator
85	161.8750	157.2750	Duplex	Marine operator
86	161.9250	157.3250	Duplex	Marine operator
87	157.3750	157.3750	Simplex	Marine operator
88	157.4250	157.4250	Simplex	Marine operator

Table 11 - USA Channel Frequencies and Channel Tag

Ch No.	RX Freq (MHz)	TX Freq (MHz)	Status	Full Name
1 "A"	156.0500	156.0500	Simplex	Vessel traffic system/ Commercial
5 "A"	156.2500	156.2500	Simplex	Vessel traffic system / Commercial
6	156.3000	156.3000	Simplex	Inter-ship safety
7 "A"	156.3500	156.3500	Simplex	Commercial
8	156.4000	156.4000	Simplex	Commercial
9	156.4500	156.4500	Simplex	Non commercial
10	156.5000	156.5000	Simplex	Commercial
11	156.5500	156.5500	Simplex	Vessel traffic system
12	156.6000	156.6000	Simplex	Vessel traffic system
13	156.6500	156.6500	Simplex, 1W	Bridge to bridge
14	156.7000	156.7000	Simplex	Vessel traffic system
15	156.7500	Inhibit	Receive Only	Environmental
16	156.8000	156.8000	Simplex	Distress, Safety, Calling
17	156.8500	156.8500	Simplex, 1W	Govt maritime control
18 "A"	156.9000	156.9000	Simplex	Commercial
19 "A"	156.9500	156.9500	Simplex	Commercial
20	161.6000	157.0000	Duplex	Port operation
20 "A"	157.0000	157.0000	Simplex	Port operation
21 "A"	157.0500	157.0500	Simplex	Coast guard only
22 "A"	157.1000	157.1000	Simplex	Coast guard
23 "A"	157.1500	157.1500	Simplex	Coast guard only
24	161.8000	157.2000	Duplex	Marine operator
25	161.8500	157.2500	Duplex	Marine operator
26	161.9000	157.3000	Duplex	Marine operator
27	161.9500	157.3500	Duplex	Marine operator
28	162.0000	157.4000	Duplex	Marine operator
63 "A"	156.1750	156.1750	Simplex	Vessel traffic system
65 "A"	156.2750	156.2750	Simplex	Port operation
66 "A"	156.3250	156.3250	Simplex	Port operation
67	156.3750	156.3750	Simplex, 1W	Bridge to bridge
68	156.4250	156.4250	Simplex	Non commercial
69	156.4750	156.4750	Simplex	Non commercial
70	(156.5250	156.5250)	DSC Only	DSC
71	156.5750	156.5750	Simplex	Non commercial
72	156.6250	156.6250	Simplex	Non commercial (ship-ship)
73	156.6750	156.6750	Simplex	Port operation
74	156.7250	156.7250	Simplex	Port operation
75	156.775	156.7750	Simplex, 1W	Port operation

Table 11 - USA Channel Frequencies and Channel Tag (cont'd)

Ch No.	RX Freq (MHz)	TX Freq (MHz)	Status	Full Name
76	156.825	156.8250	Simplex, 1W	Port operation
77	156.8750	156.8750	Simplex, 1W	Port operation (ship-ship)
78 "A"	156.9250	156.9250	Simplex	Non commercial
79 "A"	156.9750	156.9750	Simplex	Commercial
80 "A"	157.0250	157.0250	Simplex	Commercial
81 "A"	157.0750	157.0750	Simplex	Government
82 "A"	157.1250	157.1250	Simplex	Government
83 "A"	157.1750	157.1750	Simplex	Coast guard
84	161.8250	157.2250	Duplex	Marine operator
85	161.8750	157.2750	Duplex	Marine operator
86	161.9250	157.3250	Duplex	Marine operator
87	157.3750	157.3750	Simplex	Marine operator
88	157.4250	157.4250	Simplex	Commercial (ship-ship)

The "A" indicates simplex use of the ship station transmit side of an international duplex channel, and that operations are different from that of international operations on that channel.

Table 12 - Canadian Channel Frequencies and Channel Tag

Ch No.	RX Freq	TX Freq	Status	Full Name
1	160.6500	156.0500	Duplex	Marine operator
2	160.7000	156.1000	Duplex	Marine operator
3	160.7500	156.1500	Duplex	Marine operator
4 "A"	156.2000	156.2000	Simplex	Canadian coast guard
5 "A"	156.2500	156.2500	Simplex	Vessel traffic system
6	156.3000	156.3000	Simplex	Inter-ship safety
7 "A"	156.3500	156.3500	Simplex	Commercial
8	156.4000	156.4000	Simplex	Commercial
9	156.4500	156.4500	Simplex	Boater calling channel
10	156.5000	156.5000	Simplex	Commercial
11	156.5500	156.5500	Simplex	Vessel traffic system
12	156.6000	156.6000	Simplex	Vessel traffic system
13	156.6500	156.6500	Simplex, 1W	Bridge to bridge
14	156.7000	156.7000	Simplex	Vessel traffic system
15	156.7500	156.7500	Simplex	Environmental
16	156.8000	156.8000	Simplex	Distress, Safety, Calling
17	156.8500	156.8500	Simplex, 1W	State control
18 "A"	156.9000	156.9000	Simplex	Commercial
19 "A"	156.9500	156.9500	Simplex	Canadian coast guard
20	161.6000	157.0000	Duplex, 1W	Port operation
21 "A"	157.0500	157.0500	Simplex	Canadian coast guard
22 "A"	157.1000	157.1000	Simplex	Canadian coast guard
23	161.7500	157.1500	Duplex	Marine operator
24	161.8000	157.2000	Duplex	Marine operator
25	161.8500	157.2500	Duplex	Marine operator
26	161.9000	157.3000	Duplex	Marine operator
27	161.9500	157.3500	Duplex	Marine operator
28	162.0000	157.4000	Duplex	Marine operator
60	160.6250	156.0250	Duplex	Marine operator
61 "A"	156.0750	156.0750	Simplex	Canadian coast guard
62 "A"	156.1250	156.1250	Simplex	Canadian coast guard
63 "A"	156.1750	156.1750	Simplex	Port operation
64	160.8250	156.2250	Duplex	Marine operator
64 "A"	156.2250	156.2250	Simplex	Port operation
65 "A"	156.2750	156.2750	Simplex	Port operation
66 "A"	156.3250	156.3250	Simplex, 1W	Port operation
67	156.3750	156.3750	Simplex	Bridge to bridge
68	156.4250	156.4250	Simplex	Non commercial
69	156.4750	156.4750	Simplex	Non commercial
70	(156.5250	156.5250)	DSC Only	DSC

Table 12 - Canadian Channel Frequencies and Channel Tag (cont'd)

Ch No.	RX Freq	TX Freq	Status	Full Name
71	156.5750	156.5750	Simplex	Non commercial
72	156.6250	156.6250	Simplex	Non commercial
73	156.6750	156.6750	Simplex	Port operation
74	156.7250	156.7250	Simplex	Port operation
75	156.7750	156.7750	Simplex, 1W	Port operation
76	156.8250	156.8250	Simplex, 1W	Port operation
77	156.8750	156.8750	Simplex, 1W	Port operation
78 "A"	156.9250	156.9250	Simplex	Inter ship
79 "A"	156.9750	156.9750	Simplex	Inter ship
80 "A"	157.0250	157.0250	Simplex	Inter ship
81 "A"	157.0750	157.0750	Simplex	Canadian coast guard
82 "A"	157.1250	157.1250	Simplex	Canadian coast guard
83	161.7750	157.1750	Duplex	Canadian coast guard
83 "A"	157.1750	157.1750	Simplex	Canadian coast guard
84	161.8250	157.2250	Duplex	Marine operator
85	161.8750	157.2750	Duplex	Marine operator
86	161.9250	157.3250	Duplex	Marine operator
87	157.3750	157.3750	Simplex	Port operation
88	157.4250	157.4250	Simplex	Port operation

The "A" indicates simplex use of the ship station transmit side of an international duplex channel, and that operations are different from that of international operations on that channel.

NMEA Operation

This radio supports NMEA0183 version 3.01.

NMEA Input

If you have difficulty getting the UM425 to receive data from your GPS receiver, check the device's configuration. It should be set to the parameters shown in the table below.

Table 13 - NMEA Input Parameters

Baud rate	4800 bps
Data bits	8
Parity	None
Stop bits	1
Data amplitude	Over 3.0 V
Drive capability	Over 10 mA

The radio supports RMC, GLL, GNS, GGA and ZDA sentences. When these sentences are received, the radio displays latitude/longitude, date, time, course, and speed. If any sentence except an RMC or GLL sentence is received, the radio uses the information based on the following priority order.

- Status:RMC > GLL > GNS > GGA
- Latitude/Longitude:RMC > GLL > GNS > GGA
- UTC Time: RMC > GLL > GNS > GGA > ZDA
- Date: RMC > ZDA
- Speed / Course:RMC

NOTES :

- If the radio receives only a GLL sentence, the radio does not display the current speed, course, and date.
- If the radio receives both RMC and GLL sentences, the radio uses only the RMC sentence.
- Status data is used to check whether the GPS data is valid or invalid.

NMEA Output

When the radio receives a DSC call (Distress, Position Reply, or Position Send), it outputs a DSC/DSE sentence from the NMEA output port.

NOTE: When the radio receives a distress call, it outputs a sentence in the following format.

- \$CDDSC,12,3081234000,,07,00,0354013946,0657,,,S,E*6D
- \$CDDSE,1,1,A,3081234000,00,60875646*13

Regulations and Safety Warnings

Basic radio guidelines

You should familiarize yourself with the rules on marine radios and be aware of which rules apply to your boat.

DSC: Frequently Asked Questions

The following information is sourced from the Australian Maritime Safety Authority's DSC FAQ.

What is the status of VHF DSC coverage in Australia?

In Australian waters, VHF DSC is for ship-to-ship alerting. There is no official shore-based infrastructure but there are a number of volunteer marine rescue (VMR) stations that have installed VHF DSC and a check with your local VMR should be made.

VHF DSC for small craft is primarily for distress, urgency and safety purposes.

How should VHF DSC be used?

In Australian waters, Channel 70 should be used for DSC distress alerts only. Once an alert has been sent the party in distress should monitor Channel 16, the distress and calling channel. Parties receiving the DSC distress alert should switch to Channel 16 and acknowledge the MAYDAY call by voice giving their identity and signalling "Received MAYDAY". If the party in distress does not receive an acknowledgement to their DCS alert they should transmit the standard MAYDAY call by voice on Channel 16. There are still quite a number of boats that do not carry DSC radios.

Because Channel 16 is the distress and calling frequency it should only be used for general traffic to raise another party. Once contact has been made, all routine traffic should be passed on another agreed VHF channel.

Is a call sign or Maritime Mobile Service Identity (MMSI) needed?

An MMSI is a unique nine-digit code set into your DSC terminal to identify your vessel. You need only one of these if you have multiple DSC radios. You use the same MMSI for all radios on board the one vessel as it is a ship's identity. Because VHF radios now operate under a Class License there is no requirement for an official call sign but an operator must have a Maritime Radio Operators Certificate of Proficiency (MROCP).

How can a MMSI be applied for?

The Australian Maritime Safety Authority allocates MMSI. To apply for an MMSI complete the MMSI Application form available for download via **www.amsa.gov.au/mmsi**. This page has important information about MMSI and DSC radio.

What qualifications are needed to operate a VHF DSC radio?

The minimum qualification to operate a VHF radio with or without DSC is a Marine Radio Operator's VHF Certificate of Proficiency (MROVCP). VHF radios are covered by a Class License so an individual station license is no longer required.

The Marine Radio Operator's Handbook produced by the Australian Maritime College provides further information about qualifications, licensing and DSC operations. It is available at **www.amcom.amc.edu.au**

Antenna Selection and Installation

Your UM425 has been designed to accommodate all of the popular marine VHF antennas. However, the selection and the proper installation of the antenna is the responsibility of the user or installer.

The antenna used with this radio should be installed using the following guidelines to ensure a safe distance between the antenna and persons close by.

- Small whip antennas (3 dB) or smaller should be installed with at least 1m away from any area where people are likely to be.
- Larger antennas (6 dB or 9 dB) should be installed with at least 2m away.
- While the radio is transmitting, do not come closer to the antenna than the recommended safe distance.
- Do not touch the antenna when the radio is powered on and might begin transmitting.

UNIDEN UM425 VHF

IMPORTANT Satisfactory evidence of the original purchase is required for warranty service

Please refer to our Uniden website for any details or warranty durations offered in addition to those contained below.

Warrantor

The warrantor is either Uniden Australia Pty Limited ABN 58 001 865 498 ("Uniden Aust") or Uniden New Zealand Limited ("Uniden NZ") as the case may be.

Terms of Warranty

Uniden Aust/NZ warrants to the original retail purchaser only that the UM425 VHF ("the Product"), will be free from defects in materials and craftsmanship for the duration of the warranty period, subject to the limitations and exclusions set out below.

Warranty Period

This warranty to the original retail purchaser is only valid in the original country of purchase for a Product first purchased either in Australia or New Zealand and will expire two (2) years from the date of the original retail sale.

If a warranty claim is made, this warranty will not apply if the Product is found by Uniden to be:

- (A) Damaged or not maintained in a reasonable manner or as recommended in the relevant Uniden Owner's Manual;
- (B) Modified, altered or used as part of any conversion kits, subassemblies or any configurations not sold by Uniden Aust or Uniden NZ;
- (C) Improperly installed contrary to instructions contained in the relevant Owner's Manual
- (D) Repaired by someone other than an authorized Uniden Repair Agent in relation to a defect or malfunction covered by this warranty; or
- (E) Used in conjunction with any equipment, parts or a system not manufactured by Uniden.

Parts Covered

This warranty covers the Product and included accessories.

User-generated Data

This warranty does not cover any claimed loss of or damage to user-generated data (including but without limitation phone numbers, addresses and images) that may be stored on your Product.

Statement of Remedy

If the Product is found not to conform to this warranty as stated above, the Warrantor, at its discretion, will either repair the defect or replace the Product without any charge for parts or service. This warranty does not include any reimbursement or payment of any consequential damages claimed to arise from a Product's failure to comply with the warranty.

Our goods come with guarantees that cannot be excluded under the Australian Consumer Law. You are entitled to a replacement or refund for a major failure and for compensation for any other reasonably foreseeable loss or damage. You are also entitled to have the goods repaired or replaced if the goods fail to be of acceptable quality and the failure does not amount to a major failure.

This warranty is in addition to and sits alongside your rights under either the COMPETITION AND CONSUMER ACT 2010 (Australia) or the CONSUMER GUARANTEES ACT (New Zealand) as the case may be, none of which can be excluded.

Procedure for Obtaining Warranty Service

Depending on the country in which the Product was first purchased, if you believe that your Product does not conform with this warranty, you should deliver the Product, together with satisfactory evidence of your original purchase (such as a legible copy of the sales docket) to Uniden at the addresses shown below. You should contact Uniden regarding any compensation that may be payable for your expenses incurred in making a warranty claim. Prior to delivery, we recommend that you make a backup copy of any phone numbers, images or other data stored on your Product, in case it is lost or damaged during warranty service.

UNIDEN AUSTRALIA PTY LTD

Service Division
345 Princes Highway,
Rockdale, NSW 2216
Phone number: 1300 366 895
Email address: custservice@uniden.com.au

UNIDEN NEW ZEALAND LTD

Service Division
150 Harris Road, East Tamaki
Auckland 2013
Phone number: (09) 273 8377
Email address: service@uniden.co.nz

Mounting Bracket Template

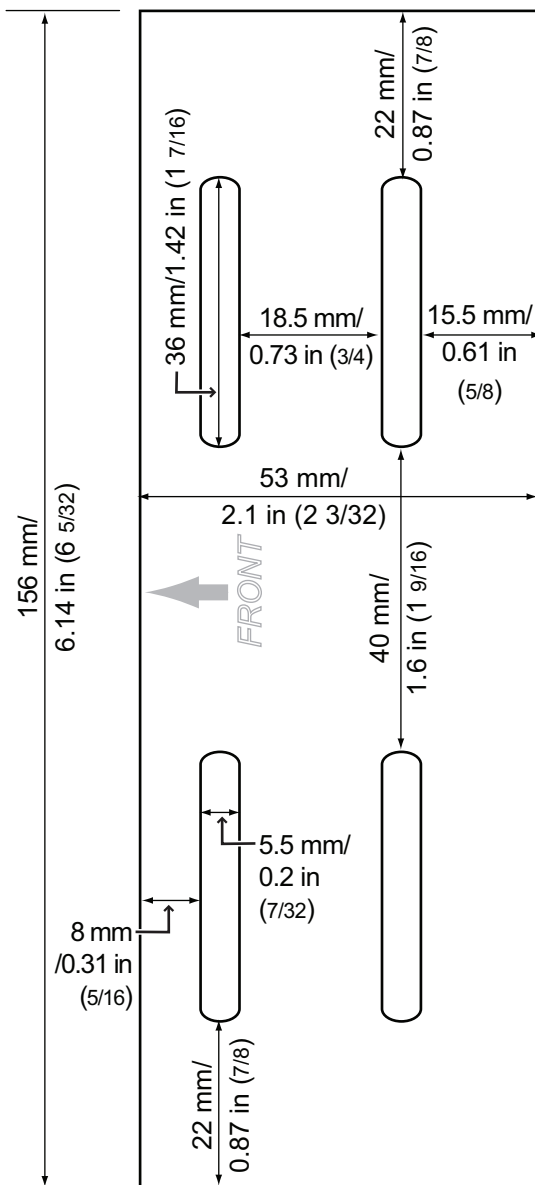

Uniden[®]

© 2011 Uniden Australia Pty Limited/Uniden New Zealand Limited
Printed in PRC UTZZ01627ZA(0)