

# Uniden®

## **UH5040** **UHF CB Transceiver**

---

For more exciting new products please visit our website:  
Australia: [www.uniden.com.au](http://www.uniden.com.au)

---

# OWNER'S MANUAL

# Contents

---

<b>Introduction</b>	<b>3</b>
Features	3
Preventive Maintenance	4
Troubleshooting	4
<b>Controls / Connectors</b>	<b>5</b>
<b>Indicators</b>	<b>6</b>
<b>Included with Your UH5040 Transceiver</b>	<b>7</b>
<b>Operation</b>	<b>8</b>
Turn ON the Power and Set the Volume	8
Setting the Squelch	8
Monitor	10
Selecting a Channel	10
Set the LCD Dimmer	10
Transmitting	11
Call Function	11
Using Repeater Channels	11
Operating the UH5040 in Duplex Mode	13
Scanning	13
Open Scan (OS) Mode	14
Group Scan (GS) Mode	15
Programming Scan Channels	16
Selecting the Call tone	16
Roger Beep	17
Busy Channel Lockout	17
Programming the Instant Priority Channel	18
Recalling the Instant Channel	18
CTCSS (Continuous Tone Coded Squelch System)	18
DCS (Digital Coded Squelch)	19
<b>UHF CB Channels &amp; Frequencies</b>	<b>20</b>
<b>CTCSS &amp; DCS Code List</b>	<b>23</b>
<b>Warranty</b>	<b>26</b>

# Introduction

---

The Uniden UH5040 is designed to provide you with years of trouble free service. Its rugged components and materials are capable of withstanding harsh environments. Please read this Operating Manual carefully to ensure you gain the optimum performance of the unit.



## NOTE

The citizen band radio service is licenced in Australia by ACMA Radio-communications (Citizen Band Radio Stations) Class Licence and in New Zealand by MED General User Licence for Citizen Band Radio and operation is subject to conditions contained in those licenses.

## Features

- Narrow Band (NB) 80 Channel Radio\*
  - Transmission Power 5W
  - Built-in AVS Circuitry†
  - LCD Display with Backlight/Dimmer
  - Signal Strength Meter
  - RF Power Meter
  - Instant Channel
  - One touch Instant Channel recalling
  - Duplex Capability (from CH01 - CH08 and CH41 - CH48 per channel)
  - Group Scan and Priority Channel Watch
  - Open Scan
  - Scan Channel Memory On/Off separately with Open Scan, Group Scan
  - Rotary Channel Select
  - Busy Channel Lock-out Function
  - Roger Beep Function On/Off
  - 5 Different Call Tones
  - 38 Built-in CTCSS (Continuous Tone Coded Squelch System) and 104 additional DCS (Digital Coded Squelch) codes that are user selectable
  - Variable Squelch Level adjust
  - Volume Control with Power On/Off Switch
- \* Refer to p.20 - p.22 for channel information
- † AVS - Automatic Volume Stabilizer detects and manages incoming audio to comparable levels.

# Introduction

---

## Preventive Maintenance

The following system checks should be made every six to twelve months:

- Check the Standing Wave Ratio (SWR).
- Inspect the tightness of all electrical connections.
- Inspect the antenna coaxial cable for wear or breaks on the shielding.
- Inspect the tightness of all screws and other mounting hardware.

## Troubleshooting

Should the unit malfunction or perform poorly, follow these procedures:  
If the transceiver is completely inoperative: Check the power cord and fuse. If there is trouble with receiving: Check the VOLUME control setting. Be sure the SQUELCH is adjusted properly. Possibly the radio is over-squelched.

If there is trouble with transmitting: Check that the transmission line (coaxial cable) is securely connected to the ANTENNA connector. Check that the antenna is fully extended for proper operation. Check that all transmission line (coaxial cable) connections are secure and free of corrosion.



### **NOTE**

Blackening may occur on the Liquid Crystal Display if the UHF CB Radio has been subjected to extreme high temperature (above 60°C). This is not a fault. Normal LCD operation resumes when the temperature stabilizes back to standard operating condition (0-55°C).

# Controls & Connectors

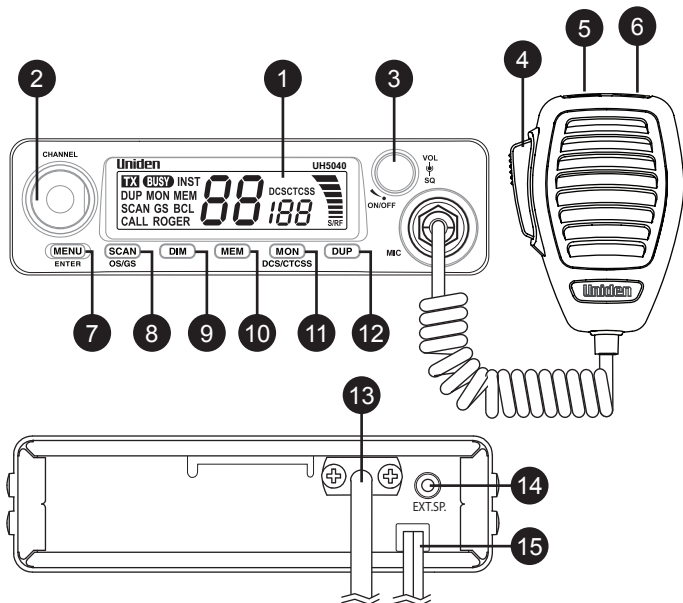

- |   |                                                        |    |                                                     |
|---|--------------------------------------------------------|----|-----------------------------------------------------|
| 1 | Liquid Crystal Display (LCD)                           | 9  | DIM - Backlight Dimmer                              |
| 2 | Rotary Channel Selector                                | 10 | MEM - Memory Scan Channels                          |
| 3 | On/Off Volume & Squelch                                | 11 | MON - DCS/CTCSS - Monitor and DCS/CTCSS Tone button |
| 4 | Push to Talk (PTT) Switch                              | 12 | DUP - Duplex On/Off                                 |
| 5 | Call Button                                            | 13 | UHF Antenna Connection                              |
| 6 | Instant Button                                         | 14 | External Speaker Jack                               |
| 7 | Menu/Enter - Select Button                             | 15 | Power Input (13.8V DC)                              |
| 8 | SCAN - Scan On/Off<br>OS/GS - Open Scan/<br>Group Scan |    |                                                     |

# Indicators

---

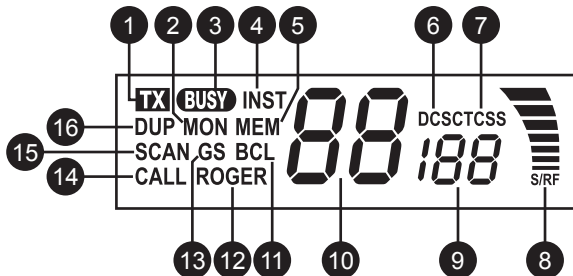

- |                                                         |                                      |
|---------------------------------------------------------|--------------------------------------|
| 1 TX - Transmit                                         | 9 <i>188</i> - DCS/CTCSS Code number |
| 2 MON - Monitor                                         | 10 <i>88</i> - Channel Number        |
| 3 BUSY - Receiving                                      | 11 BCL - Busy Channel Lockout        |
| 4 INST - Instant Channel                                | 12 ROGER - Roger Beep                |
| 5 MEM - Memory Scan Channel                             | 13 GS - Group Scan                   |
| 6 DCS - Digital Coded Squelch System                    | 14 CALL - Call Tone                  |
| 7 CTCSS - Continuous Tone Coded Squelch System          | 15 SCAN - Scan Mode                  |
| 8 S/R - Receive Signal or Transmit RF Power Level Meter | 16 DUP - Duplex                      |

# Included with your UH5040 Transceiver

---



Standard Microphone

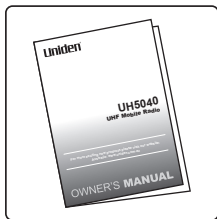

Owner's Manual

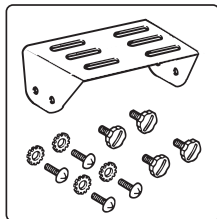

Mounting Bracket,  
Mounting Screws,  
Washer Stars  
And Screws

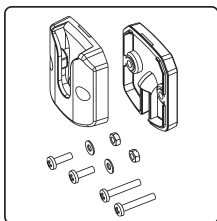

Microphone Hanger &  
Screws Washers and  
spare fuse

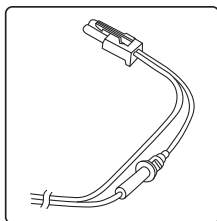

DC Power Cord  
with fuse

## Optional Accessories

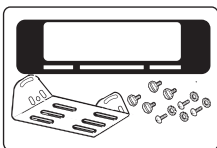

DIN Mounting Kit  
(DMK8990)



External Speaker  
(MS100)

# Operation

---

## Turn on the Power and set the Volume

Turn the unit ON by rotating the volume control clockwise. Set the volume to a desired level.



## Setting the Squelch

Turn the outer ring of the control to adjust the Squelch.



**NOTE**

You must select a channel which is not in use before setting the SQUELCH control. (see below for "Selecting a Channel").



# Operation

---

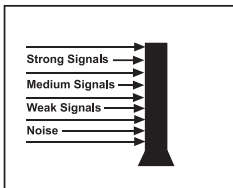

Think of the squelch control as a gate. If you turn Squelch fully clockwise it raises the 'Squelch gate' so high that no signals get through.

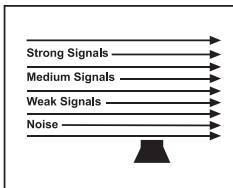

If you turn the Squelch fully counterclockwise it lowers the 'Squelch Gate' to the extent that all signals get through - weak, medium and strong signals and noise.

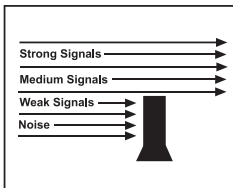

To set the 'Squelch Gate' to the desired level, turn the squelch knob counterclockwise until you hear noise. Then carefully turn the Squelch knob clockwise until the noise fades. Now only strong signals get through.

# Operation

## Monitor

Press **[MON]** to open the squelch and receive all weak signals. Press **[MON]** again momentarily to cancel.



## Selecting a Channel

Turn the Rotary Channel Selector to select the desired channel.

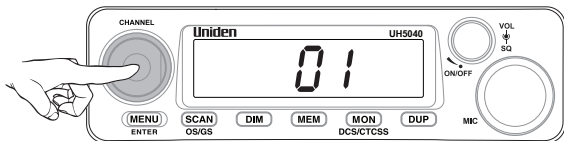

**NOTE**

For your reference a list of the available channels, corresponding frequencies and guidelines for their use is printed on page 20. For Australia, Channels 05 and 35 are reserved for Emergency Calls.

## Set the LCD Dimmer

Press **[DIM]** to set the LCD backlight dimmer between high and low.

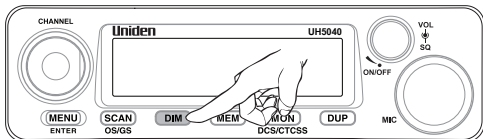

# Operation

---

## Transmitting

The UH5040 uses the 80 UHF-CB Channels  
**For your reference a list of the available channels, corresponding frequencies and guidelines for their use and selection is printed on page 20. For Australia, Channels 05 and 35 are reserved for Emergency Calls.**

Select the desired channel. Press the microphone's PTT button and speak normally into the microphone. Hold it approx. 7cm from your mouth. Release the PTT button to end the transmission and listen for a reply.

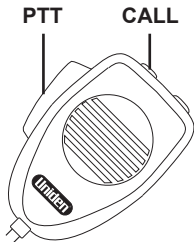

## Call Function

Press the microphone Call Button. A two second ringing tone will be transmitted. You may select from 5 types of tones (see p.16).

**Current regulations require calling tones to be restricted to one transmission per minute. If a second transmission is attempted within one minute then an error tone will sound.**

## Using Repeater Channels

UHF CB repeaters are used to retransmit or relay your signal. Repeaters will extend the range of your radio and overcome the shielding effect caused by solid obstructions. In normal Simplex operation, your radio transmits on one particular frequency and receives on that same frequency. If there is a barrier that partially blocks your transmitted signal, the probability of another radio receiving the signal is very slim. Hills, tall buildings, metallic structures,...etc tend to act as a screen between radios.

# Operation

---

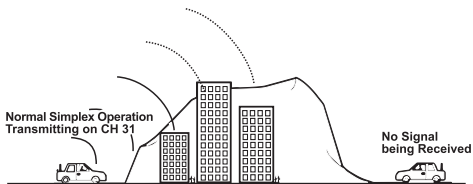

Standard Operation without the aid of a Repeater station.

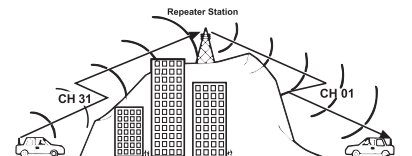

Operation with the aid of a Repeater Repeater Station (Duplex).

The signal coming from your radio is received by the Repeater Station and the re-transmitted at the same time on another channel. This operation is called "Duplexing".

For example,

CH01 on Duplex Mode will Receive on CH01 but Transmit on CH31  
CH02 on Duplex Mode will Receive on CH02 but Transmit on CH32  
etc...

**If you transmit on CH01 Duplex mode, you are actually transmitting on CH31 the repeater station down-converts your signal and retransmits on CH01.**

# Operation

## Operating the UH5040 in Duplex Mode

For this example we are adopting CH01 as the channel being used in your area for repeater use.

Press **[DUP]** to switch Duplex On. If Duplex is not required - press **[DUP]** again to switch Duplex off. Only channels 01-08 and channels 41-48 are available for Duplex.



**NOTE**

Check with your local Retailer for information on available repeaters.

## Scanning

The UH5040 has a scanning feature that allows you to search for active channels automatically.

Furthermore, the UH5040 is designed to have two types of scanning; Open Scanning (OS) and Group Scanning (GS), to give you flexibility and allow you to use the radio more effectively. Press **[SCAN]** and Scanning starts. The **SCAN** icon appears. The scan direction can be changed at any time by rotating the channel selector left or right.



# Operation

---

## Open Scan (OS) Mode

Allows continuous scanning of all selected channels.

If an active channel is found, scanning will stop on that channel.

If the received signal ceases, the unit will wait 3 seconds for the signal to return, otherwise scanning resumes.

To skip the active channel, press **[MEM]** momentarily. Scanning resumes. To deactivate SCAN, press **[SCAN]** or the PTT button on the microphone.



**NOTE**

If SCAN is deactivated while on an active channel, the UH5040 will stay on that active channel. If no channels are active, the UH5040 will reinstate the starting channel.



**NOTE**

OS Mode is indicated by the absence of the GS icon.

# Operation

---

## Group Scan (GS) Mode

Allows you to monitor a Priority (Instant) Channel while scanning (Instant Priority channel see p. 18).

To use GS Mode Scanning, press **[OS/GS]**. GS icon appears on the display.

GS Scanning checks the Instant Priority Channel for activity regularly.

If the Priority Channel becomes active the radio will stay on that channel for as long as the signal is present. If the received signal ceases, Priority Scanning continues after 3 seconds.

If scanning stops on a channel which is not a Priority Channel, UH5040 will continue monitoring the Priority Channel for activity while listening to the active one.

To deactivate SCAN, press the **[SCAN]** button or the PTT button on the microphone.



**NOTE**

If SCAN is deactivated while it is tuned to an active channel, the UH5040 will stay on that active channel.

If none of the channels are active, the UH5040 will reinstate the scan start channel.



**NOTE**

If OS/GS Scanning is initiated when there are no channels programmed in OS/GS memory, an error tone will be heard and scanning will not start (see Programming Scan Channels - below).

# Operation

## Programming Scan Channels

Select which Scanning Mode you wish to use - OS or GS.

Select the channel you want to store.

Press **[MEM]** to store. MEM icon appears and a short tone beep is heard.

To remove the channel from Memory, press **[MEM]** once more. The MEM icon disappears.

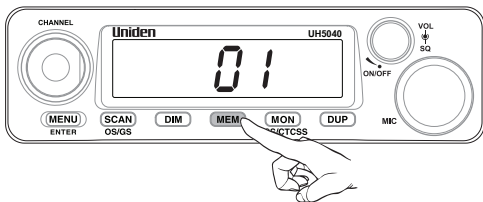

## Selecting the Call tone

Press **[MENU]** once. Turn the Rotary Channel Selector to change the setting between 1, 2, 3, 4 and 5. Press and hold **[MENU]** for 3 seconds to store the new setting.

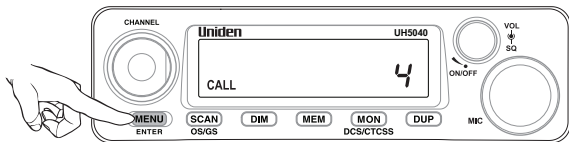

**NOTE**

If a button is not pressed within 10 seconds the UH5040 will automatically exit the Menu Mode.



# Operation

## Roger Beep

A Roger Beep may be added to the end of transmission.

Press **[MENU]** twice. Turn the Channel Selector to display **0n**.

Press and hold **[MENU]** for 3 seconds to store the new setting.

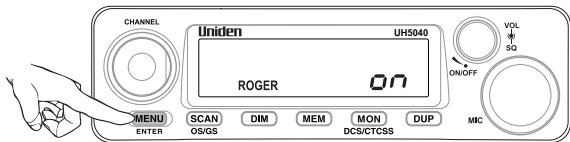

**NOTE**

If a button is not pressed within 10 seconds the UH5040 will automatically exit the Menu Mode.

## Busy Channel Lockout

If the channel is already in use, you can prevent the UH5040 from transmitting. This is particularly important when using CTCSS.

Press **[MENU]** 3 times. Turn the Rotary Channel Selector to display **0n**.

Press and hold **[MENU]** for 3 seconds to store the new setting.

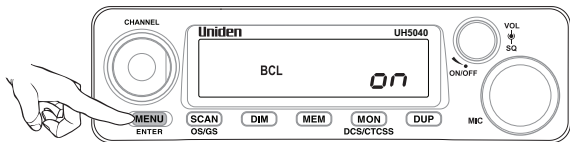

**NOTE**

If a button is not pressed within 10 seconds the UH5040 will automatically exit the Menu Mode.

# Operation

---

## Programming the Instant Priority Channel

Turn the Rotary Channel Selector to select the Priority Channel you prefer.

Press and hold **[INST]** button on the microphone for 3 seconds to store the new setting. INST icon appears.

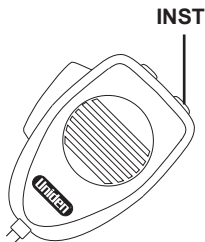

## Recalling the Instant Channel

Momentarily press the **[INST]** button on the microphone at any time to return to the Instant Channel.

## CTCSS (Continuous Tone Coded Squelch System)

Turn the Rotary Channel Selector to the desired channel to use CTCSS.

Press and hold **[MON]** for 3 seconds. CTCSS icon appears.

Turn the Rotary Channel Selector to select the desired CTCSS code 01 - 38.

Press **[MON]** once to store the new setting. To turn off CTCSS (or DCS) select the oF code during setting.

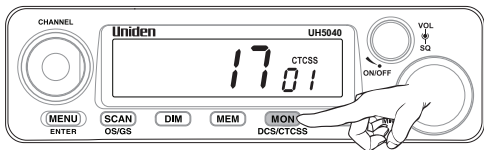

# Operation

---

## DCS (Digitally Coded Squelch)

DCS is a digital extension of CTCSS. It provides 104 extra, digitally coded, squelch codes that follow after the 38 CTCSS codes. CTCSS 1-38, followed by DCS 1-99 plus DCS 100-104 (represented by o0-o4 on the display).

Follow the steps for setting a CTCSS code. Turn the Rotary Channel Selector until the DCS codes appear. Press **[MON]** to set. The **DCS** icon and code will display.



**NOTE**

Channels 5 and 35 are used for emergency channels. CTCSS and DCS will not operate on these channels.

# UHF CB Channel Guidelines

---

Always listen on a channel (or observe the receive signal level meter) to ensure it is not already being used before transmitting.

Channels 5 and 35 are used for emergency channels. CTCSS and DCS will not operate on these channels.

Please follow these guidelines for channel use in Australia:

- Channels 05 and 35 are Emergency Channels.
- Channel 11 is a Calling Channel.
- Channels 22 and 23 are for telemetry and telecommand applications, channels 61, 62 and 63 are for future use and TX is inhibited on these channels.



**NOTE**

General communication is accepted on all other channels with these guidelines:

- Channel 40 - road channel (Australia).
- Channels 01-08 (and 31-38), and Channels 41-48 (and 71-78) are repeater channels.

## **Important information - 80 Channel UHF CB channel expansion**

To provide all users additional channel capacity within the UHF CB Band. The ACMA will change the majority of the current wideband 40 channel use to narrowband channel use. This allows for additional channels to be added, up to 80 Channels.

This simply means that the new narrowband radio you have purchased will have more channels than older radios. Please refer to the guidelines above and the channel chart for further channel information.

A list of currently authorised channels can also be obtained from the ACMA website in Australia and the MED website in New Zealand.



**NOTE**

## **Interference / Poor Audio**

When a new narrowband radio receives a signal from an older wideband radio the speech may sound loud - however the UH5040's built-in AVS (Automatic Volume Stabilizer) circuitry will detect and manage incoming audio to comparable levels.

Narrowband radios operating on CH41 - CH80 may encounter interference from a nearby wideband radios transmitting on high power on an adjacent channel (frequency).

When an older wideband radio receives a signal from a new narrowband radio the speech may sound quiet - the wideband radio user simply adjusts their radio volume for best performance.

The above situations are not a fault of the radio but a symptom of mixed wideband and narrowband radios in current use. It is expected that as older wideband radios are phased out this issue will be eliminated.

# UHF CB Channels & Frequencies

CH No.	Simplex Mode Transmit / Receive Frequency (MHz)	Duplex Mode Transmit Frequency (MHz)	CH No.	Simplex Mode Transmit / Receive Frequency (MHz)
1	476.425	477.175 (CH31)	21	476.925
2	476.450	477.200 (CH32)	22	476.950 (RX only)
3	476.475	477.225 (CH33)	23	476.975 (RX only)
4	476.500	477.250 (CH34)	24	477.000
5	476.525	477.275 (CH35)	25	477.025
6	476.550	477.300 (CH36)	26	477.050
7	476.575	477.325 (CH37)	27	477.075
8	476.600	477.350 (CH38)	28	477.100
9	476.625		29	477.125
10	476.650		30	477.150
11	476.675		31	477.175
12	476.700		32	477.200
13	476.725		33	477.225
14	476.750		34	477.250
15	476.775		35	477.275
16	476.800		36	477.300
17	476.825		37	477.325
18	476.850		38	477.350
19	476.875		39	477.375
20	476.900		40	477.400

# UHF CB Channels & Frequencies

CH No.	Simplex Mode Transmit / Receive Frequency (MHz)	Duplex Mode Transmit Frequency (MHz)	CH No.	Simplex Mode Transmit / Receive Frequency (MHz)
41	476.4375	477.1875 (CH 71)	61	future use 476.9375 (RX only)
42	476.4625	477.2125 (CH 72)	62	future use 476.9625 (RX only)
43	476.4875	477.2375 (CH 73)	63	future use 476.9625 (RX only)
44	476.5125	477.2625 (CH 74)	64	477.0125
45	476.5375	477.2875 (CH 75)	65	477.0375
46	476.5625	477.3125 (CH 76)	66	477.0625
47	476.5875	477.3375 (CH 77)	67	477.0875
48	476.6125	477.3625 (CH 78)	68	477.1125
49	476.6375		69	477.1375
50	476.6625		70	477.1625
51	476.6875		71	477.1875
52	476.7125		72	477.2125
53	476.7375		73	477.2375
54	476.7625		74	477.2625
55	476.7875		75	477.2875
56	476.8125		76	477.3125
57	476.8375		77	477.3375
58	476.8625		78	477.3625
59	476.8875		79	477.3875
60	476.9125		80	477.4125

# CTCSS codes table

Code No.	Frequency (Hz)	Code No.	Frequency (Hz)
"oF"	OFF	20	131.8
1	67.0	21	136.5
2	71.9	22	141.3
3	74.4	23	146.2
4	77.0	24	151.4
5	79.7	25	156.7
6	82.5	26	162.2
7	85.4	27	167.9
8	88.5	28	173.8
9	91.5	29	179.9
10	94.8	30	186.2
11	97.4	31	192.8
12	100.0	32	203.5
13	103.5	33	210.7
14	107.2	34	218.1
15	110.9	35	225.7
16	114.8	36	223.6
17	118.8	37	241.8
18	123.0	38	250.3
19	127.3		

## DCS codes table

Code No.	DCS Code (Octal)	Code No.	DCS Code (Octal)	Code No.	DCS Code (Octal)
1	023	36	223	71	445
2	025	37	225	72	446
3	026	38	226	73	452
4	031	39	243	74	454
5	032	40	244	75	455
6	036	41	245	76	462
7	043	42	246	77	464
8	047	43	251	78	465
9	051	44	252	79	466
10	053	45	255	80	503
11	054	46	261	81	506
12	065	47	263	82	516
13	071	48	265	83	523
14	072	49	266	84	526
15	073	50	271	85	532
16	074	51	274	86	546
17	114	52	306	87	565
18	115	53	311	88	606
19	116	54	315	89	612
20	122	55	325	90	624
21	125	56	331	91	627
22	131	57	332	92	631
23	132	58	343	93	632
24	134	59	346	94	654
25	143	60	351	95	662
26	145	61	356	96	664
27	152	62	364	97	703
28	155	63	365	98	712
29	156	64	371	99	723
30	162	65	411	100	731
31	165	66	412	101	732
32	172	67	413	102	734
33	174	68	423	103	743
34	205	69	431	104	754
35	212	70	432		





# Warranty

---

## UNIDEN UH5040 UHF CB Transceiver

**IMPORTANT: Satisfactory evidence of the original purchase is required for warranty service**

Please refer to our Uniden website for any details or warranty durations offered in addition to those contained below.

**Warrantor:** The warrantor is Uniden Australia Pty Limited ABN 58 001 865 498 (“Uniden Aust”).

**Terms of Warranty:** Uniden Aust warrants to the original retail purchaser only that the UH5040 (“the Product”), will be free from defects in materials and craftsmanship for the duration of the warranty period, subject to the limitations and exclusions set out below.

**Warranty period:** This warranty to the original retail purchaser is only valid in the original country of purchase for a Product first purchased either in Australia or New Zealand and will expire, as indicated below, from the date of original retail sale.

Product	5 Years
Accessories	1 Year

If a warranty claim is made, this warranty will not apply if the Product is found by Uniden to be:

- (A) Damaged or not maintained in a reasonable manner or as recommended in the relevant Uniden Owner’s Manual;
- (B) Modified, altered or used as part of any conversion kits, subassemblies or any configurations not sold by Uniden Aust;
- (C) Improperly installed contrary to instructions contained in the relevant Owner’s Manual
- (D) Repaired by someone other than an authorized Uniden Repair Agent in relation to a defect or malfunction covered by this warranty; or
- (E) Used in conjunction with any equipment, parts or a system not manufactured by Uniden.

# Warranty

---

**Parts Covered:** This warranty covers the Product and included accessories.

**User-generated Data:** This warranty does not cover any claimed loss of or damage to user-generated data (including but without limitation phone numbers, addresses and images) that may be stored on your Product.

**Statement of Remedy:** If the Product is found not to conform to this warranty as stated above, the Warrantor, at its discretion, will either repair the defect or replace the Product without any charge for parts or service. This warranty does not include any reimbursement or payment of any consequential damages claimed to arise from a Product's failure to comply with the warranty.

Our goods come with guarantees that cannot be excluded under the Australian Consumer Law. You are entitled to a replacement or refund for a major failure and for compensation for any other reasonably foreseeable loss or damage. You are also entitled to have the goods repaired or replaced if the goods fail to be of acceptable quality and the failure does not amount to a major failure.

This warranty is in addition to and sits alongside your rights under either the COMPETITION AND CONSUMER ACT 2010 (Australia) or the CONSUMER GUARANTEES ACT (New Zealand) as the case may be, none of which can be excluded.

**Procedure for obtaining warranty service:** Depending on the country in which the Product was first purchased, if you believe that your Product does not conform with this warranty, you should deliver the Product, together with satisfactory evidence of your original purchase (such as a legible copy of the sales docket) to Uniden. Please refer to the Uniden website for address details. You should contact Uniden regarding any compensation that may be payable for your expenses incurred in making a warranty claim. Prior to delivery, we recommend that you make a backup copy of any phone numbers, images or other data stored on your Product, in case it is lost or damaged during warranty service.

## **UNIDEN AUSTRALIA PTY LTD**

Phone: 1300 366 895

Email: [custservice@uniden.com.au](mailto:custservice@uniden.com.au)

**THANK YOU FOR BUYING A UNIDEN PRODUCT.**

**Uniden®**

© 2015 Uniden Australia Pty Limited. Printed in Vietnam.  
U01UT949AZZ(0)