

Uniden®

SSE34
Series

*For more exciting new products please visit our website:
Australia: www.uniden.com.au*

OWNER'S MANUAL

IMPORTANT SAFETY INSTRUCTIONS

When using your telephone equipment, basic safety precautions should always be followed to reduce the risk of fire, electric shock and injury to persons, including the following:

- **This unit is NOT waterproof.** DO NOT expose this unit to moisture.
- DO NOT expose this unit to rain.
- Do not use this product near water, for example, near a bath tub, wash bowl, kitchen sink or laundry tub, in a wet basement or near a swimming pool.
- Avoid using a telephone (other than a cordless type) during an electrical storm. There may be a remote risk of electric shock from lightning.
- Do not use the telephone to report a gas leak in the vicinity of the leak.
- Avoid sources of noise and heat, such as motors, fluorescent lighting, microwave oven, heating appliances, and direct sunlight.
- Avoid areas of excessive dust, moisture, and low temperatures.
- Never install telephone jacks in wet locations unless the jack is specifically designed for wet locations.
- Never touch non-insulated telephone wires or terminals, unless the telephone line has been disconnected at the network interface.
- Use caution when installing or modifying telephone lines.

SAVE THESE INSTRUCTIONS!

WHAT'S IN THE BOX?

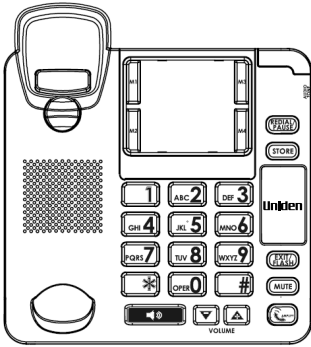

SSE34 base



Handset

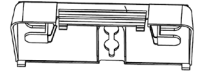

Desk Stand
(might be
attached to base)



Handset Cord



Telephone
Line Cord

- If any item is missing or damaged, contact your place of purchase immediately. Never use damaged products!
- Need help? Get answers at our website:
www.uniden.com.au for Australian model

CONTENTS

INSTALLING YOUR PHONE	5
Connect the Telephone	5
Wall Mounting.....	6
BASE LAYOUT.....	7
Front View	7
Back View	8
Side View	8
BASIC FUNCTIONS.....	9
Speakerphone	9
Placing a Call	9
Answering A Call.....	10
Volume.....	10
Amplified Audio.....	10
Audio Tone Control.....	11
Mute.....	11
Flash.....	11
Redial.....	11
Memory.....	12
Adding a Pause to the Dialling Sequence.....	12
Changing a Stored Number.....	12
Dialling a Number from Memory.....	12
TROUBLESHOOTING	13
ONE-YEAR LIMITED WARRANTY	14

INSTALLING YOUR PHONE

Connecting the Telephone

1. Choose an area near a telephone wall jack (RJ11C), and place your cordless telephone on a level surface, such as a desktop or tabletop, or you may mount it on the wall.
2. Plug one end of the telephone line cord into the Line jack at the back of the base and the other end into a modular jack.
3. If you have another device (example, an additional auxiliary phone or data modem) need to be connected to the unit, please connect it to the Data jack on the back of the unit.
4. Connect one end of the coiled handset cord to the jack on the handset.
5. Plug the other end of the coiled handset cord to the jack on the base.
6. Adjust the RINGER VOLUME switch to the desired setting: HIGH, LOW or OFF.

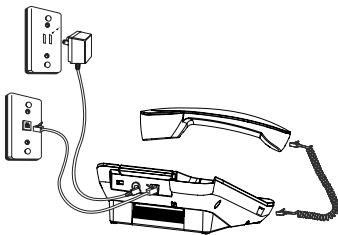

The unit is properly installed if you pick up the handset and hear the dial tone. If you don't hear a dial tone, recheck all the installation steps.

 **The unit is shipped from the factory for placement on a level surface.**

Wall Mounting

To detach the desktop pedestal:

1. Rotate the hook 180°.
2. Plug one end of the straight telephone line cord into the jack on the bottom of the base.
3. Feed the line cord through the groove and plug the end into the modular telephone jack. Excess telephone line can be stuffed into the recess area on the bottom of the Base Unit.
4. Slip the mounting holes (on the bottom of the base) over the wall plate posts and firmly slide the unit down into place.

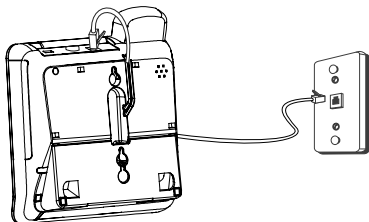
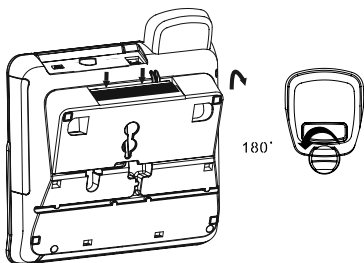

BASE LAYOUT

FRONT VIEW

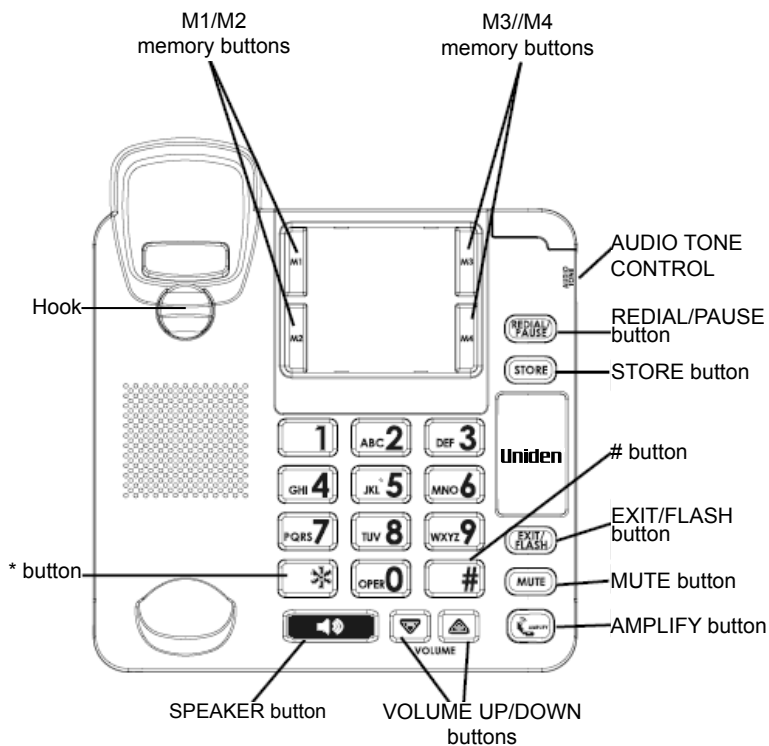

BACK VIEW

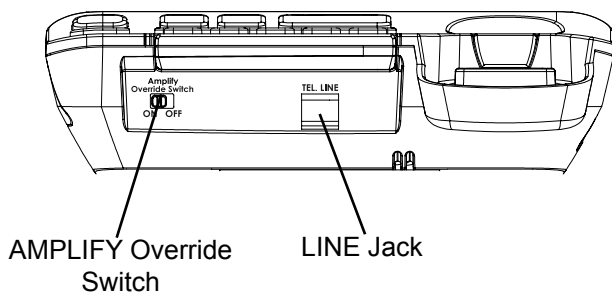

SIDE VIEW

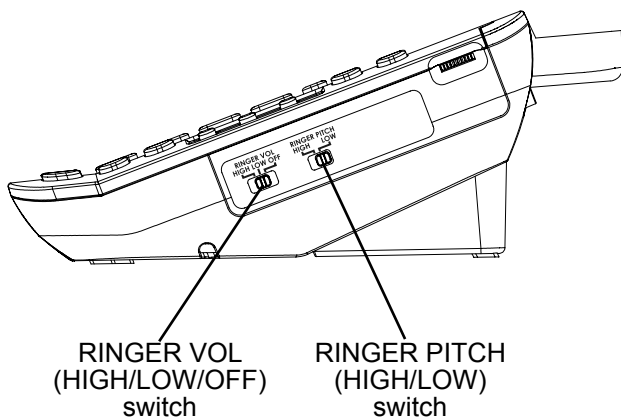

BASIC FUNCTIONS

Speakerphone

For hands-free operation and convenience, this unit is equipped with a speakerphone.

For best speakerphone performance, avoid the following:

- Areas with high background noise. (The microphone might pick up these sounds and prevent the speakerphone from going into the receiving mode when you finish talking.)
- Surfaces affected by vibration.
- Recessed areas such as in a corner, under a cupboard, or next to a cabinet, which can generate an echo effect.

Note the following guidelines when using the speakerphone:

- The speakerphone works similar to a two-way radio in that you can only listen or talk at one time.
- Stay reasonably close to the phone so that you can be clearly heard by the person to whom you are talking.
- You can adjust the speaker volume by adjusting the volume (▲ or ▼) buttons while speakerphone is in use.
- The speakerphone indicator comes on when the speakerphone is in use.

Placing a Call

Handset

1. Pick up the handset and listen for a dial tone.
2. Dial the number you want to call.
3. When finished, hang up the handset.

Speakerphone

1. Press the speaker button on the base and listen for a dial tone.
2. Dial the number you want to call.
3. When finished, press the speaker button to hang up.

Answering a Call

Handset

1. When the phone rings, pick up the handset.
2. When finished, hang up the handset.

Speakerphone

1. When the phone rings, press the speaker button to answer a call.
2. When finished, press the speaker button to hang up.

You may switch between the speakerphone and the handset during the dialing process or anytime during a conversation.

Speakerphone to Handset -Pick up the handset to disable the speakerphone. The speakerphone indicator turns off.

Handset to Speakerphone -Press the speaker button, and then hang up the handset. The speakerphone indicator turns on and the handset is disabled.

 **NOTE: Make sure the ringer switch is set to HI or LO, or the phone will not ring.**

The visual ring indicator will flash at all settings

Volume

You can control the volume of both the handset receiver and the speakerphone. While using the handset or speakerphone, you may adjust the volume to the desired listening level by using the volume (▲or ▼) buttons. Handset volume has 4 levels for adjustment and Speaker volume has 8 levels.

Amplified Audio

You may press the amplify button to temporarily boost the volume of the handset receiver during a call. To return to normal levels, press the button again. Volume levels will also return to normal when handset is replaced on base after call. The “AMPLIFY” button controls the increased volume level and audio tone of the handset.

1. Press the volume (▲or ▼) button to minimum, pick up the handset and press the amplify button to turn on the incoming voice amplifier. The indicator around the button illuminates.
2. Adjust the volume by pressing the volume (▲or ▼) button. When the amplify button is pressed , an extra level of amplified volume is added providing up to 20dB of gain and level control. In standard use, the amplifier turns off whenever you hang up the telephone. If you want the amplifier to turn on whenever you pick up the handset , slide the Amplify Override switch located at the back of the unit to ON.

 **NOTE: AMPLIFY feature is working in Handset Mode only.**

 **WARNING: This Product is designed for users with hearing disabilities and automatically amplifies the volume to the highest level when the AMPLIFY Override switch is set to “ON”. If you wish to prevent the automatic amplification, please turn the AMPLIFY Override switch located on the back of the set to “OFF”.**

Audio Tone Control

The phone's Audio Tone Control boosts the sound of the frequency range from 600Hz to 3KHz to compensate for the ear's limited sensitivity in the range.

1. To turn on the Audio Tone Control, press the "amplify" button after you pick up the handset, or any time during the a call. The indicator around the button illuminates.
2. To adjust the setting, rotate the Audio Tone Control to select the specific frequency range.
3. To turn off the Audio Tone Control press the "amplify" button and the indicator light turns off.

Mute

Use the mute button to interrupt a phone conversation to talk privately with someone else in the room. A conversation can be muted while using the speakerphone, handset or neck loop.

1. Press the mute button. The mute indicator illuminates.
2. Press mute again to turn it off.

 **Note: Switching from speakerphone to handset cancels mute.**

Flash

Press the flash button to activate customer calling services such as call waiting.

Redial

You may redial the last number you called by pressing the redial button after you get a dial tone.

 **NOTE: The Redial feature holds in memory the last phone number you dialed (as many as 32 digits). If you pressed any numbers after dialing the phone number, (for example, when accessing a voice-menu system) those numbers also are redialed.**

Memory

Store as many as 4 numbers in memory for easy dialing. They can be stored the one-touch memory on the top of the Base unit. You can use the space provided to either write the name of your contacts or stick pictures for easy recognition.

Storing a Number in Memory

1. Pick up the handset or press SPEAKER.
2. Press the STORE button.
3. Dial the number to be stored (up to 16 digits).
4. Select and press any of the one-touch Memory Location buttons.
5. Hang up the phone or press the SPEAKER button.

Adding a Pause to the Dialing Sequence

Use the PAUSE button to insert a delay in the dialing sequence when storing a number, for example, when you need to dial 9 to get an outside line.

Pause function is enabled when the #pause button is pressed and held for 2 seconds.

Press and hold PAUSE button at the point in the dialing sequence in which a pause is required.

The pause time is approximately four seconds, if additional time is needed, press and hold the PAUSE button again.

Changing a Stored Number

Follow the same steps as "Storing a Number into Memory." The new numbers will overwrite the existing numbers.

Dialing a Number from Memory

You can dial numbers from memory when using the handset or speakerphone. When you get a dial tone, press the one-touch memory button for the number you want to dial.

TROUBLESHOOTING

Problems	Possible Solutions
No Dial Tone	<ul style="list-style-type: none">• Check installation: Make sure the telephone line cord is connected to the base unit and the wall phone jack.• Check the hook switch. Make sure it fully extends when the handset is lifted from the cradle.• You must have touch-tone service on your line to use this phone. If you do not know what type of service you have, check with the phone company.• Make sure speakerphone indicator comes on (if using speakerphone.)• Unplug the phone, wait 30 seconds, and plug the phone back in. Then lift the handset to check the dial tone.• Connect another phone to the same modular jack; if the second phone doesn't work, the problem might be with your wiring or local service.• Place the handset in the base for at least 20 seconds.
Phone doesn't ring	<ul style="list-style-type: none">• Make sure ringer switch is set to LO or HI.• You may have too many extension phones on your line. Unplug some extension phones.• Check for a dial tone. If there is no dial tone, see solutions for "No dial tone."
Low volume on speaker/handset	Check the receiver or speaker volume settings.
Can't be heard by other party	<ul style="list-style-type: none">• Make sure phone cord is securely plugged in.• Make sure extension phones are on the hook at the same time you're using the phone. It is normal for the volume to drop when additional extension phones are used at the same time.
Memory Dialing	<ul style="list-style-type: none">• Make sure you entered numbers correctly. (See "Memory" in page 12)• Make sure the telephone is properly installed. Pick up the handset and listen for the dial tone. If you don't hear the dial tone, recheck or repeat the installation steps.

ONE-YEAR LIMITED WARRANTY

SSE34

IMPORTANT Satisfactory evidence of the original purchase is required for warranty service

Please refer to our Uniden website for any details or warranty durations offered in addition to those contained below.

Warrantor

The warrantor is Uniden Australia Pty Limited ABN 58 001 865 498 (“Uniden Aust”).

Terms of Warranty

Uniden Aust warrants to the original retail purchaser only that the SSE34 (“the Product”), will be free from defects in materials and craftsmanship for the duration of the warranty period, subject to the limitations and exclusions set out below.

Warranty Period

This warranty to the original retail purchaser is only valid in the original country of purchase for a Product first purchased either in Australia or New Zealand and will expire one (1) year from the date of the original retail sale.

If a warranty claim is made, this warranty will not apply if the Product is found by Uniden to be:

- (A) Damaged or not maintained in a reasonable manner or as recommended in the relevant Uniden Owner’s Manual;
- (B) Modified, altered or used as part of any conversion kits, subassemblies or any configurations not sold by Uniden Aust;
- (C) Improperly installed contrary to instructions contained in the relevant Owner’s Manual
- (D) Repaired by someone other than an authorized Uniden Repair Agent in relation to a defect or malfunction covered by this warranty; or
- (E) Used in conjunction with any equipment, parts or a system not manufactured by Uniden.

Parts Covered

This warranty covers the Product and included accessories.

User-generated Data

This warranty does not cover any claimed loss of or damage to user-generated data (including but without limitation phone numbers, addresses and images) that may be stored on your Product.

Statement of Remedy

If the Product is found not to conform to this warranty as stated above, the Warrantor, at its discretion, will either repair the defect or replace the Product without any charge for parts or service. This warranty does not include any reimbursement or payment of any consequential damages claimed to arise from a Product's failure to comply with the warranty.

Our goods come with guarantees that cannot be excluded under the Australian Consumer Law. You are entitled to a replacement or refund for a major failure and for compensation for any other reasonably foreseeable loss or damage. You are also entitled to have the goods repaired or replaced if the goods fail to be of acceptable quality and the failure does not amount to a major failure.

This warranty is in addition to and sits alongside your rights under either the COMPETITION AND CONSUMER ACT 2010 (Australia) or the CONSUMER GUARANTEES ACT (New Zealand) as the case may be, none of which can be excluded.

Procedure for Obtaining Warranty Service

Depending on the country in which the Product was first purchased, if you believe that your Product does not conform with this warranty, you should deliver the Product, together with satisfactory evidence of your original purchase (such as a legible copy of the sales docket) to Uniden. Please refer to the Uniden website for address details. You should contact Uniden regarding any compensation that may be payable for your expenses incurred in making a warranty claim. Prior to delivery, we recommend that you make a backup copy of any phone numbers, images or other data stored on your Product, in case it is lost or damaged during warranty service.

UNIDEN AUSTRALIA PTY LTD

Phone number: 1300 366 895

Email address: custservice@uniden.com.au

Uniden[®]

©2016 Uniden Australia Pty Ltd
Printed in PRC