

# Uniden®

## QUICK START GUIDE

### G110 - OUTDOOR IMITATION CAMERA

#### SAFETY INSTRUCTIONS

- ◆ This unit, if not installed properly, maybe defective.
- ◆ This camera is powered by AA batteries only. Do not use any power adaptor.
- ◆ When installing batteries (not supplied), please ensure that they are inserted with proper orientation.
- ◆ This equipment is NOT waterproof. DO NOT expose it to excessive water or moisture.
- ◆ If any items are missing or damaged, contact your place of purchase immediately. **Never use damaged products!**
- ◆ Need help? Get answers at our website:  
[www.uniden.com.au](http://www.uniden.com.au) for Australian model  
[www.uniden.co.nz](http://www.uniden.co.nz) for New Zealand model.

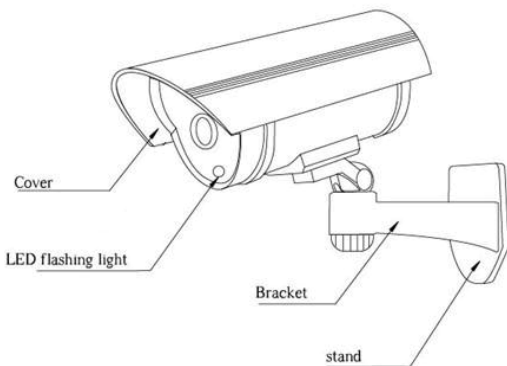

- ✗ **Once the batteries have been installed, the LEDs will blink at an interval of 3 seconds.**

## INSTALLATION

To install the batteries, open the casing and then insert two AA batteries (not supplied) with proper orientation.

Use the screws provided to fix the stand to a base.

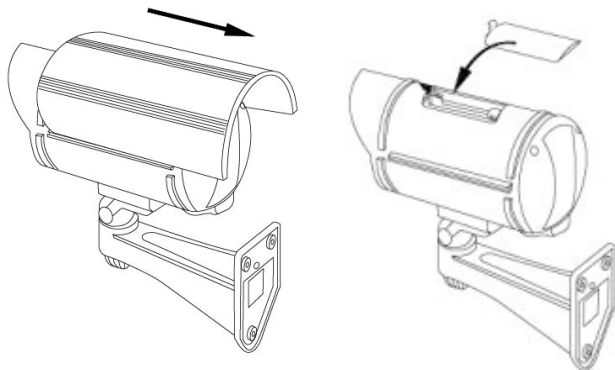

## SPECIFICATIONS

Material	ABS
Colour	Black
Camera Stand	3-Axis, ABS
Camera Lens & LEDs	Plastic
Power Source	2 x 1.5V AA batteries
On/Off Method	Installation/Removal of batteries
Accessories	Mounting Hardware
Weatherproof Housing	IP44 (splash proof)
Unit N.W	300g

# ONE-YEAR LIMITED WARRANTY

## UNIDEN G110 Outdoor Imitation Camera

### Important:

Satisfactory evidence of the original purchase is required for warranty service. Please refer to our Uniden website for any details or warranty durations offered in addition to those contained below.

### Warrantor:

The warrantor is either Uniden Australia Pty Limited ABN 58 001 865 498 (“Uniden Aust”).

**Terms of Warranty:** Uniden Aust warrants to the original retail purchaser only that the G110 (“the Product”), will be free from defects in materials and craftsmanship for the duration of the warranty period, subject to the limitations and exclusions set out below.

**Warranty Period:** This warranty to the original retail purchaser is only valid in the original country of purchase for a Product first purchased either in Australia or New Zealand and will expire one (1) year from the date of the original retail sale. If a warranty claim is made, this warranty will not apply if the Product is found by Uniden to be:

- A. Damaged or not maintained in a reasonable manner or as recommended in the relevant Uniden Owner’s Manual;
- B. Modified, altered or used as part of any conversion kits, subassemblies or any configurations not sold by Uniden Aust;
- C. Improperly installed contrary to instructions contained in the relevant Owner’s Manual
- D. Repaired by someone other than an authorized Uniden Repair Agent in relation to a defect or malfunction covered by this warranty; or
- E. Used in conjunction with any equipment, parts or a system not manufactured by Uniden.

**Parts Covered:** This warranty covers the Product and included accessories.

**User-generated Data:** This warranty does not cover any claimed loss of or damage to user-generated data (including but without limitation phone numbers, addresses and images) that may be stored on your Product.

**Statement of Remedy:** If the Product is found not to conform to this warranty as stated above, the Warrantor, at its discretion, will either repair the defect or replace the Product without any charge for parts or service. This warranty does not include any reimbursement or payment of any consequential damages claimed to arise from a Product's failure to comply with the warranty. Our goods come with guarantees that cannot be excluded under the Australian Consumer Law. You are entitled to a replacement or refund for a major failure and for compensation for any other reasonably foreseeable loss or damage. You are also entitled to have the goods repaired or replaced if the goods fail to be of acceptable quality and the failure does not amount to a major failure. This warranty is in addition to and sits alongside your rights under either the COMPETITION AND CONSUMER ACT 2010 (Australia) or the CONSUMER GUARANTEES ACT (New Zealand) as the case may be, none of which can be excluded.

**Procedure for Obtaining Warranty Service:** Depending on the country in which the Product was first purchased, if you believe that your Product does not conform with this warranty, you should deliver the Product, together with satisfactory evidence of your original purchase (such as a legible copy of the sales docket) to Uniden at the addresses shown below. You should contact Uniden regarding any compensation that may be payable for your expenses incurred in making a warranty claim. Prior to delivery, we recommend that you make a backup copy of any phone numbers, images or other data stored on your Product, in case it is lost or damaged during warranty service.

**UNIDEN AUSTRALIA PTY LTD**

Phone number: 1300 366 895

Email: [custservice@uniden.com.au](mailto:custservice@uniden.com.au)